

LRT SERIES

ROUGH TERRAIN SCISSOR LIFTS



Performance

Platform Height—Elevated		
330LRT	33 ft	10.06 m
430LRT	43 ft	13.11 m
530LRT	53 ft	16.2 m
Platform Capacity		
330LRT	2,250 lb	1,020 kg
430LRT/530LRT	1,500 lb	680 kg
Capacity on Platform Extension	500 lb	227 kg
Capacity with Dual Extensions		
330LRT	2,000 lb	907 kg
430LRT	1,250 lb	567 kg
530LRT	1,250 lb	567 kg
Number of Occupants	6	
Lift/Lower Time		
330LRT	35/32 seconds	
430LRT	45/42 seconds	
530LRT	65/60 seconds	
Maximum Drive Height		
330LRT/430LRT	Full Height	
530LRT	32 ft	9.75 m
Weight w/One Extension*		
330LRT	11,820 lb	5,372 kg
430LRT	14,300 lb	6,486 kg
530LRT	17,000 lb	7,711 kg
Ground Bearing Pressure		
330LRT	73 psi	5.1 kg/cm ²
430LRT	83 psi	5.8 kg/cm ²
530LRT	90 psi	6.3 kg/cm ²
Drive Speed	3.5 mph	5.6 km/h
Gradeability		
330LRT/430LRT	45%	
530LRT	40%	
Tilt Rating		
330LRT	3.0 degrees	
430LRT	3.0 degrees	
530LRT	1.5 degrees	
Turning Radius (Inside)		
330LRT/430LRT	8 ft 10.5 in.	2.7 m
530LRT	9 ft	2.7 m
Turning Radius (Outside)		
330LRT/430LRT	19 ft 5.5 in.	5.9 m
530LRT	19 ft 9 in.	6.0 m

* Certain options or country standards will increase weight.

Standard Specifications

Engine

Make and Model		
Dual Fuel – Kubota WG972	31 hp	23.2 kW
Diesel Fuel – Kubota D1305	24.8 hp	18.5 kW
Fuel Tank Capacity	22 gal.	83.3 L



Tires

Standard	
330LRT/430LRT	33 x 15.5 Superwide/12 x 16.5 Foam-filled
530LRT	12 x 16.5 Foam-filled

Brakes

- Rear Wheel Spring Applied

Hydraulic System

- Capacity 32 gal. 121.4 L

Standard Features

- 4-Wheel Drive
- Automatic Transmission
- Three-speed Drive Select
- Proportional Drive/Lift Up/Lift Down
- Oscillating Axle
- 76 x 154 in. (1.95 x 3.92 m) Platform
- 4 ft (1.22 m) Manual Deck Extension
- 110V-AC Receptacle in Platform
- 73.5 x 156 in. (1.87 x 3.96 m) All-Steel Platform³
- Adjustable, Removable Platform Control Station
- Fold-Down Handrails
- Horn
- Tilt Light and Alarm
- All Motion Alarm

Accessories & Options

- Leveling Jacks¹
- Dual Extension Deck
- 1/2 in. Airline to Platform
- Flashing Amber Beacon
- 43.5 lb (19.7 kg) Propane Tank
- Cold Weather Start Kit
- 7500 Watt Generator
- Pipe Rack
- Large Material Rack

1. Standard on 530LRT
2. Not available on 530LRT
3. Only available on 530LRT



760 rue Bériault, Longueuil, Québec (Canada) J4G 1R8
1-833-360-3330 | info@sosequipment.ca

LRT SERIES

ROUGH TERRAIN SCISSOR LIFTS



Dimensions

All dimensions are approximate.

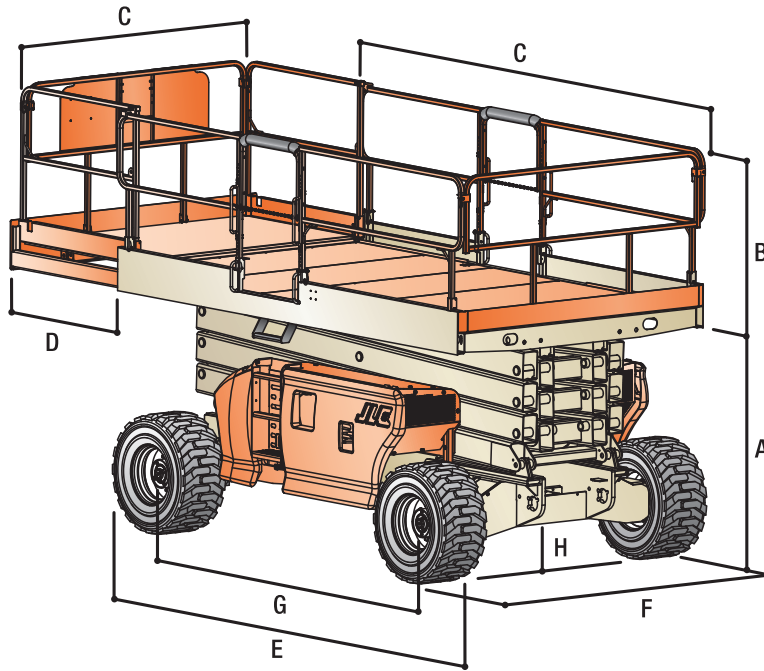

Platform Height — Elevated

330LRT	33 ft	10.1 m
430LRT	43 ft	13.1 m
530LRT	53 ft	16.2 m

A. Platform Height — Lowered

330LRT	5 ft 3.4 in.	1.6 m
430LRT	6 ft 5 in.	1.8 m
530LRT	6 ft 7 in.	2.0 m

B. Platform Railing Height

	3 ft 7.5 in.	1.1 m
--	--------------	-------

C. Platform Size

330LRT/430LRT	70.5 x 149.8 in.	1.8 x 3.8 m
530LRT	73.5 x 156 in.	1.9 x 4.0 m

D. Platform Extension

	4 ft	1.2 m
--	------	-------

E. Overall Length

330LRT/430LRT	12 ft 10 in.	3.9 m
530LRT	16 ft	4.9 m

F. Overall Width

330LRT/430LRT	7 ft 9 in.	2.4 m
530LRT	7 ft 7 in.	2.3 m

G. Wheelbase

	9 ft 9 in.	3.0 m
--	------------	-------

H. Ground Clearance

330LRT/430LRT	13.6 in.	34.5 cm
530LRT	12 in.	30 cm

The JLG "1 & 5" Warranty

We provide coverage for one (1) full year, and cover all specified major structural components for five (5) years. Due to continuous product improvements, we reserve the right to make specification and/or equipment changes without prior notification. This machine meets or exceeds applicable ANSI and CSA requirements based on machine configuration as originally manufactured for intended applications. Please reference the serial number plate on the machine for additional information.

Part No.: 3131581
R1219_A92.20
Printed in USA



JLG Industries, Inc.

1 JLG Drive
McCconnellsburg, PA 17233-9533
Telephone 717-485-5161
Toll-free in US 877-JLG-LIFT
Fax 717-485-6417
www.jlg.com

An Oshkosh Corporation Company