

MULTI LOADER DER 2.5

PATENT PENDING



2.5 PERFORMANCE

SOSEQUIPMENT

VENTE | LOCATION | SERVICE | TRANSPORT

1-833-360-3330 | INFO@SOSEQUIPMENT.CA

CRAWLER CARRIER

ALMACRAWLER 

MULTI LOADER 2.5

Tracked transporter with patented bi-levelling technology.
Full electric with radio remote control.

Loading capacity 2500 kg

The unique and innovative ML 2.5 allows you to safely transport loads and equipment up to 2.5 tonnes.

Crawler traction and bi-levelling technology

The unique crawler traction allows easy access and travelling on different types of terrain and on steep slopes, ensuring manoeuvrability and precision even in the narrowest spaces, to get your loads safely to destination.



Dynamic Levelling

The patented technology allows the ML 2.5 to maintain a horizontal load-deck thanks to the automatic levelling (Dynamic Levelling) up to 20° longitudinal and 14° lateral.

Through this technology we ensure the safe movement of the load being carried at all times.



Autonomy and auxiliary engine

The innovative Lead Cristal Battery Power-Pack (48V-180Ah) provides 10 hours of working time in mixed cycle, allowing a maximum speed of 2.2 km/h.

The high-frequency battery charger is installed inside the chassis and allows full recharging in only 5 hours.

The 110V or 220V electric pump gives the possibility of using the ML 2.5 without depleting the battery.

External and internal use

Full electric and silent, the new Multi-Loader range allows both external and internal applications and uses.

Dati tecnici**Performance****Technical data**

Portata	2.500 kg	Max Capacity
Altezza minima	0.74 m	Max working height
Larghezza minima	1.46 m	Min Width
Larghezza massima	1.64 m	Max Width
Dynamic levelling	Si / Yes	Dynamic Levelling
Autonomia	10 h	Battery autonomy
Motorizzazione (elettropompa)	48V-3kW	Powered (electric engine)
Pacco batterie	Lead Crystal n°8 180Ah 48V	Battery pack
Caricabatterie	n°2 20Ah 48V	Battery charger
Tempo di ricarica	5 h	Recharging time
Comandi	Remote	Console
Sottocarro cingolato	Bi-Levelling	Undercarriage
Livellamento longitudinale Anteriore	20°	Longitudinal levelling Front
Livellamento longitudinale Posteriore	15°	Longitudinal levelling Rear
Livellamento laterale	+/- 14°	Lateral levelling
Elettropompa	220V-2kW or 110V-1,9kW	Electric pump (option)
Comandi idraulici	Proporzionali / Proportionals	Hydraulic commands
Direction-Control System	Si / Yes	Direction-Control System
Easy-Drive System	Si / Yes	Easy-Drive System
Kit per doppia velocità	max 2.20 km/h	Kit for high speed
Controllo dell'inclinazione	Autom.	Control of inclination
Pendenza superabile	25°	Gradeability
Massima pendenza laterale	25°	Side slope
Lunghezza	2.40 m	Length
Massa complessiva	1800 kg	Total weight

Trasportatore cingolato con tecnologia brevettata bi-levelling. Full electric e radiocomandato.

Capacità di carico - 2500 kg

Il nuovo ML 2.5 offre la possibilità di trasportare in sicurezza carichi e attrezzature con un peso massimo di 2.5 tonnellate.

Trazione cingolata e tecnologia bi-levelling

La trazione cingolata permette di operare su tutte le tipologie di terreno e su pendenze considerevoli, garantendo la possibilità di manovrare con facilità e precisione, anche in spazi estremamente ridotti, carichi ingombranti.

Dynamic Levelling fino a 20° di inclinazione

La tecnologia brevettata AlmaCrawler permette al ML 2.5 di mantenere il pianale orizzontale grazie al livellamento automatico (Dynamic Levelling) fino a 20° longitudinali e 14° laterali.

In questo modo si compensano contemporaneamente pendenze longitudinali e laterali, garantendo l'assoluta integrità del materiale movimentato.

Autonomia e motore ausiliario

L'innovativo Lead Crystal Battery Power-Pack (48V-180Ah) assicura fino a 10 ore di operatività in ciclo misto, potendo usufruire di una velocità massima di spostamento di 2.2 Km/h.



Il carica batterie ad alta frequenza installato direttamente all'interno dello chassis consente la ricarica completa in sole 5 ore.

L'elettropompa 110V o 220V permette di utilizzare il trasportatore senza assorbire la carica delle batterie.

Utilizzo esterno ed interno

Ecologica e silenziosa, la nuova gamma Multi-Loader offre soluzioni sia per utilizzi in ambienti esterni che interni.

MULTI LOADER 2.5 PERFORMANCE

2.5t	5h
CAPACITY	RECHARGE
10h	
AUTONOMY	LONG. LEVEL.
2.2km/h	
SPEED	LATER. LEVEL.

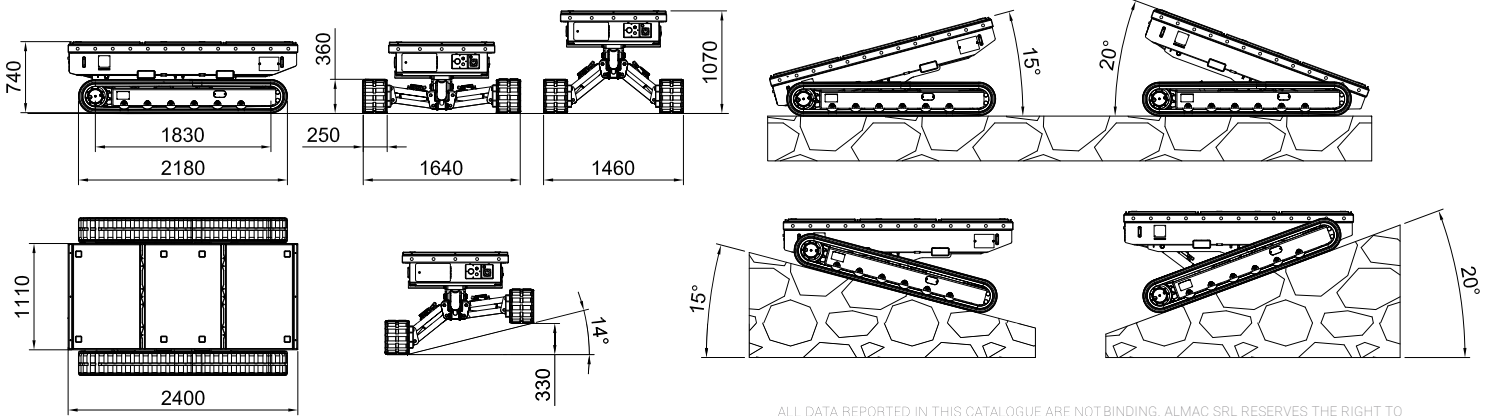

ALL DATA REPORTED IN THIS CATALOGUE ARE NOT BINDING. ALMAC SRL RESERVES THE RIGHT TO CHANGE SPECIFICATIONS WITHOUT PRIOR NOTICE.

Kits and options

- Maxi-chassis with ramps
- Electric winch
- Tow hook
- Telaio allargato con rampe
- Verricello elettrico
- Gancio di traino



Maxi-chassis with ramps

Chassis W = 1,30 mt L = 2,45 mt
Ramps W = 0,36 mt L = 2,50 mt

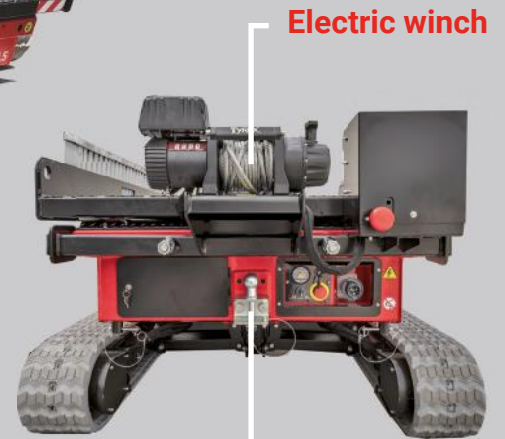

Electric winch

Tow hook

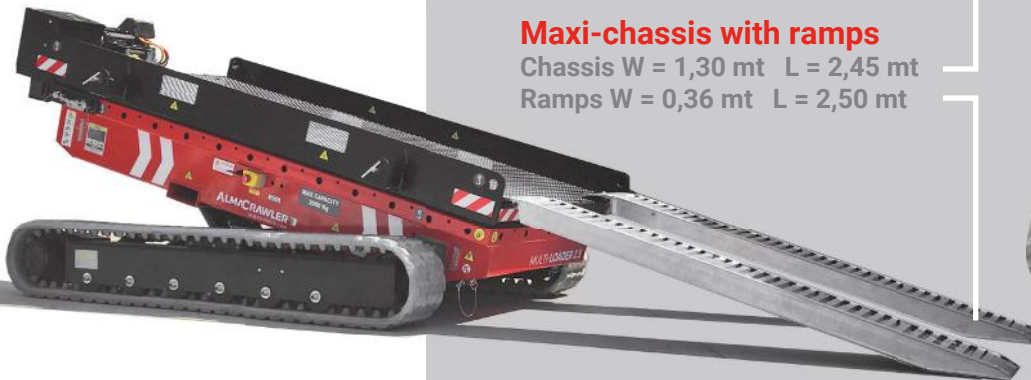

Via Caduti sul Lavoro 1
46019 Viadana (MN) - ITALY
+39 0375 83 35 27
info@almac-italia.com

SOSlocation.ca
VENTE · LOCATION · SERVICE · TRANSPORT
1-833-360-3330

ALMACRAWLER 