

# ML-LINE

## MULTI-LOADER 6.0



**SOSEQUIMENT**

VENTE | LOCATION | SERVICE | TRANSPORT  
1-833-360-3330 | INFO@SOSEQUIMENT.CA

**ALMACRAWLER**

# MULTI-LOADER 6.0

**Multi-Loader is the last generation tracked crawler carriers, equipped with bi-levelling system and radio-controlled.**

## Loading capacity

The new Multi-Loading tracking system offers the possibility to handle different types of loads up to 6 t of weight.

## Crawler traction and low ground pressure

The unique Bi-Lavelling crawler traction allow the carrier to operate on all different type of terrain, ensuring the maximum manoeuvrability and precision even in the narrowest spaces, with the minimum ground pressure.

## Dynamic Levelling

The levelling of the load-deck is completely automatic when using the Dynamic Levelling System even on slopes or uneven surfaces.

Multi-Loader can overcome both longitudinal slopes until 20° and lateral slopes until 25° at the same time, always ensuring the absolute integrity of the load being carried.

## Engines available

The Multi-Loader 6.0 is available in 3 versions with different types of engines.

The full electric model, the **Multi Loader ELC**, has the innovative Lead Crystal n°8 180Ah 48V provides 8 hours of working time in mixed cycle, taking advantage of a maximum movement speed of 2.6 km/h.

An High-Frequency battery charger directly installed inside the main chassis, allows the full charge of the Multi-Loader in only 5 hours, while an auxiliary mains electric pump 220V-2,2 kW enables the possibility to use the carrier also during the battery charging.

The **Multi Loader EVO** equipped with high-performance internal combustion engine Yanmar 3TNV76 (diesel) - 25HP, reaches maximum speeds of 3.7 km/h. This model is especially suitable for outside use.

The **Multi Loader Bi-Energy** have a double motorization, thermic and electric, that provides full versatility, both for inside or outside applications.



# MULTI-LOADER 6.0 ELC

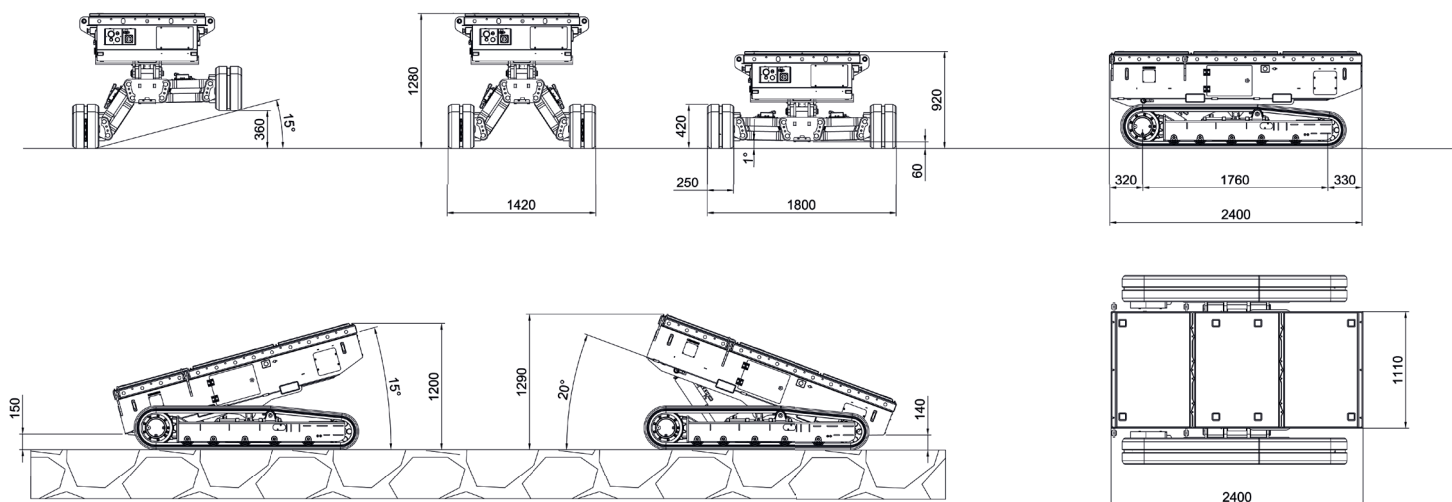

Technical data	MULTI-LOADER 6.0 ELC	MULTI-LOADER 6.0 EVO	MULTI-LOADER 6.0 Bi-Energy	MULTI-LOADER 6.0 Bi-Energy with crane
Max capacity	6000 kg	6000 kg	6000 kg	5500 kg
Min height	0.92 m	1.44 m	1.44 m	2.61 m
Min width	1.42 m	1.42 m	1.42 m	1.42 m
Max width	1.8 m	1.8 m	1.8 m	1.8 m
Dynamic levelling	Yes	Yes	Yes	Yes
Battery autonomy	8 h	-	5 h	5 h
Powered	-	Yanmar 3TNV76 (diesel) - 25HP	Yanmar 3TNV76 (diesel) - 25HP	Yanmar 3TNV76 (diesel) - 25HP
Powered (electric engine)	48V - 3kW	-	48V - 3kW	48V - 3kW
Battery pack	Lead Crystal n°8 180Ah 48V	-	Lead Crystal n°8 180Ah 48V	Lead Crystal n°8 180Ah 48V
Battery charger	n°2 20Ah-110/220V	-	n°2 20Ah-110/220V	n°2 20Ah-110/220V
Recharging time	5 h	-	5 h	5 h
Console	Remote	Remote	Remote	Remote
Undercarriage	Bi-Levelling	Bi-Levelling	Bi-Levelling	Bi-Levelling
Longitudinal levelling Front	20°	20°	20°	20°
Longitudinal levelling Rear	15°	15°	15°	15°
Lateral levelling	+/- 15°	+/- 15°	+/- 15°	+/- 15°
Electric pump	-	220V-2kW or 110V-1,9kW	-	-
Hydraulic commands	Proportionals	Proportionals	Proportionals	Proportionals
Direction-Control System	Yes	Yes	Yes	Yes
Easy-Drive System	Yes	Yes	Yes	Yes
Kit for high speed	max 2.6 km/h	max 3.7 km/h	max 3.7 km/h	max 3.7 km/h
Control of inclination	Automatic	Automatic	Automatic	Automatic
Gradeability	25°	25°	25°	25°
Side slope	25°	25°	25°	25°
Length	2.4 m	3.0 m	3.0 m	3.0 m
Total weight	2250 kg	2250 kg	2550 kg	2990 kg

## MULTI-LOADER 6.0 EVO / BI-ENERGY

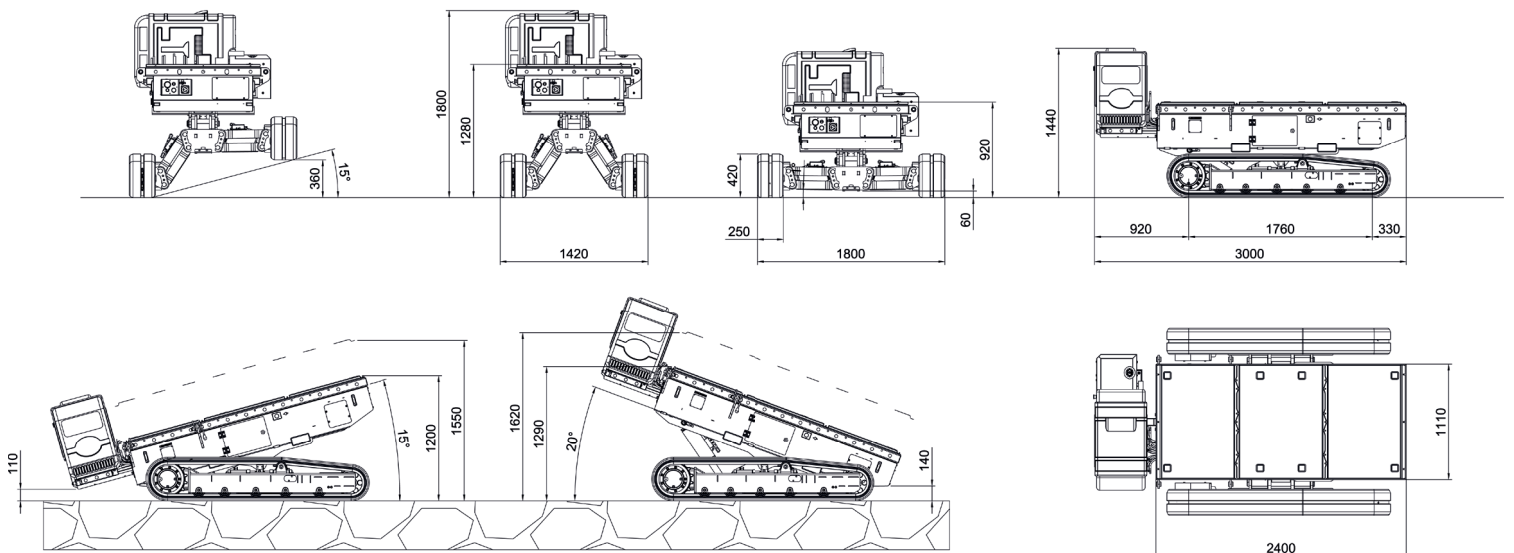



# 4.1 T-CRANE MULTI-LOADER 6.0

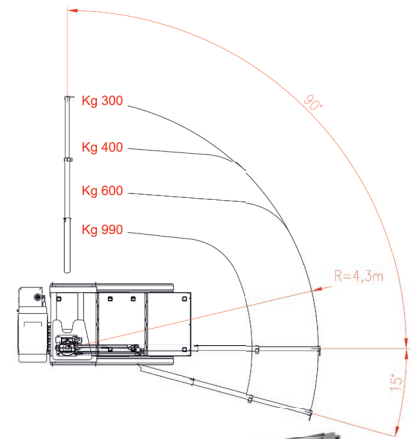
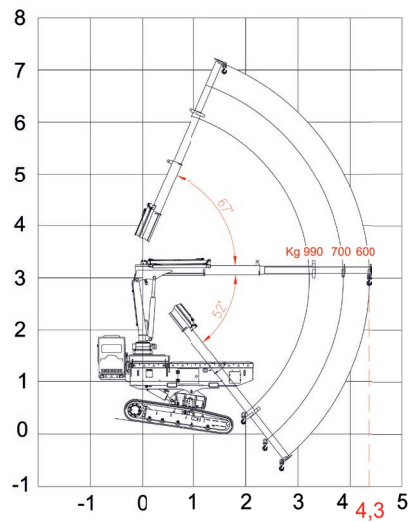
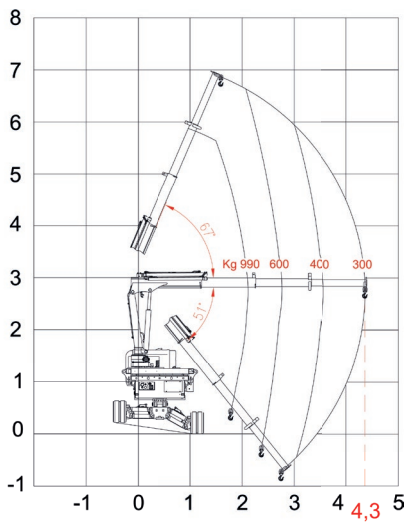
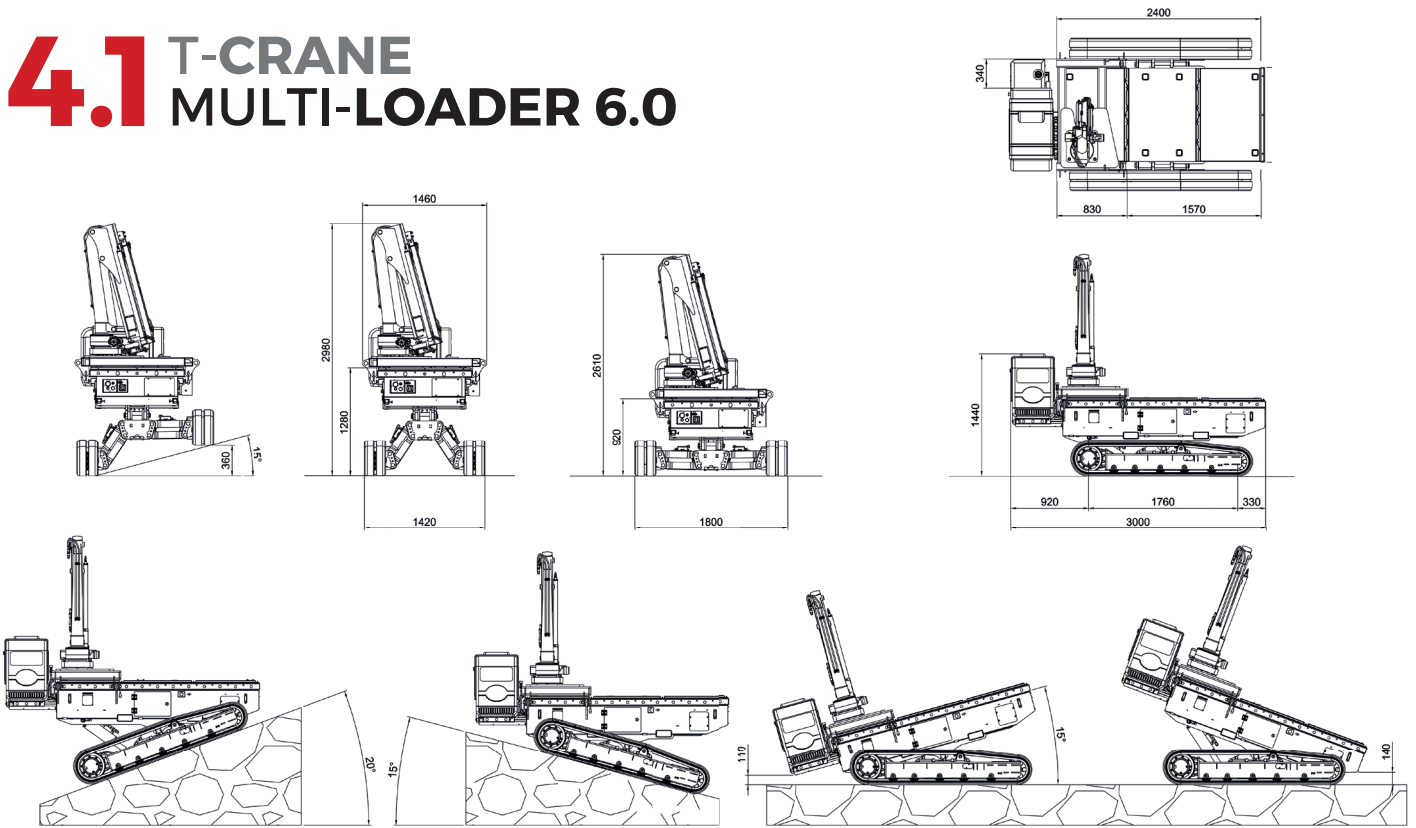

## T-CRANE kit (removable) Self-propelled crane

### Standard version

- Cable transducer for extension
- Absolute encoder for turrent rotation
- Inclination sensor for boom angle

### Optional

- Personalised colour

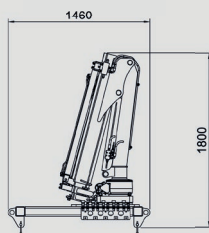

Max capacity  
5.5 ton.

Max outreach 4.3 m  
Max capacity 990 kg

Weight  
460 kg

