

SL 608 Outdoor
lifts up to 1340 lb

SL 608 Outdoor

for outdoor and indoor use

A powerful lift suitable for outdoor use

SL 608 Outdoor is suitable for outdoor lifting assignments for example on construction sites. The lift is the second most powerful in the Smartlift range with a lifting capacity up to 1340 lb.

- Off road with front-wheel drive
- Maneuverable with dual rear wheels
- Foam filled tires
- Self-driven
- Electronic brake
- Lifting height 116 in (center of yoke)
- 2 vacuum circuits with 2 pumps
- 4 Suction pads Ø 15.8 in
- Ergonomic operation handle
- Waterproof according to ip65



Larger window sections and heavier windows with up to three layers of glass still call for even stronger lifting capacity. SL 608 Outdoor is a power lift in the Outdoor range and in terms of size it is positioned between the SL 380 Outdoor and the SL 780 Outdoor Giant



The Smartlift is easily transported in a van or on a trailer

SOSEQUIMENT

VENTE | LOCATION | SERVICE | TRANSPORT
1-833-360-3330 | INFO@SOSEQUIMENT.CA

Smart Lift
DENMARK

SL 608 Outdoor

The lift has 3.9 in sideshift for accurate adjustment when fitting the window



The vacuum system is separated into two vacuum circuits for highest security. Showing vacuum circuits with blue and red vacuum hoses



The yoke has movements in all directions



For high security the stabilizers of the lift are equipped with mandrels to fasten on stable ground for better stability.

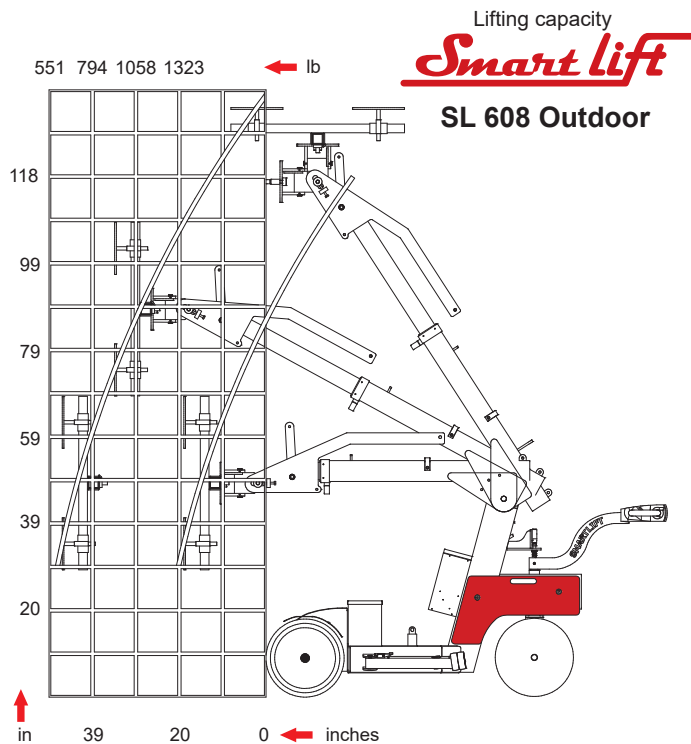

Technical data

Description	Value
Weight	1830 lb
Height	60.3 in
Width (min)	32.7 in
Length (min)	92.2 in
Extension of arm	27.6 in
Tip from horizontal	30° back/95° forward
Speed regulation	Stepless high/low
Sideshift	3.9 in
Vacuum system	2 circuits
Lifting height mounting	137.9 in
Charging voltage	115 volt
Integrated charger	Blue Power 24/12
Charging time	Approx 8 hours
Battery (2 x 12v) 24 volt	2 x 105 Ah
Running period	Approx 20 hours
Front-wheel drive	1.61 hp
Brake	Elektronic
Suction pads	4 unit Ø 15.8 in
Lifting capacity arm in/extended (27.6 in)	1340 lb/617 lb

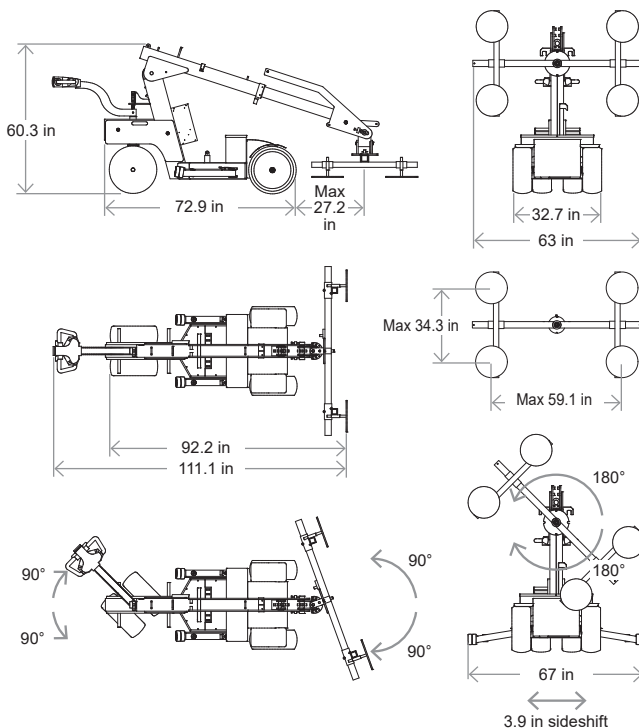

19/1020

SOSEQUIPMENT

VENTE | LOCATION | SERVICE | TRANSPORT
1-833-360-3330 | INFO@SOSEQUIPMENT.CA

Smart lift
DENMARK