

Righetti

Model smart vacuum lifters

VB4 RCMBM

The VB4 is a below-the-hook vacuum lifter suitable for lifting and handling glass units weighing up to 400 kg. Vacuum glass lifter VB4 RCMBM is **powered by rechargeable batteries** that, if necessary, may be easily removed and quickly replaced (battery charger included).

The 4 suction pads are repositionable in **two different positions**: when the lifter is closed the pads spread is 863x666 mm; when the lifter is open the pads spread is 1166x861 mm.

The VB4 RCMBM vacuum lifter features **manual tilt** and **manual 360° rotation**. Its compact and flat design permit that VB4 could work also behind scaffoldings. VB4 is specific vacuum glass lifter for construction site use with **dual vacuum circuit** according to EN13155 standard.

Vacuum glass lifter



Kg max
400



Power supply
Batteries

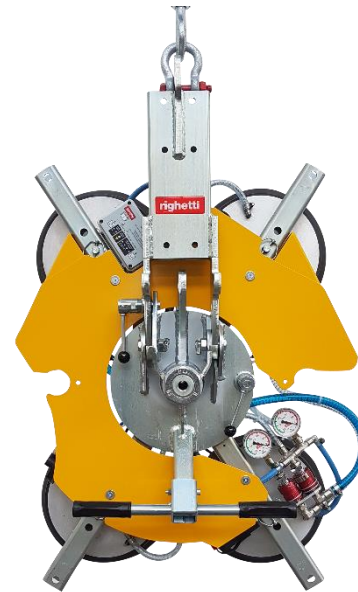
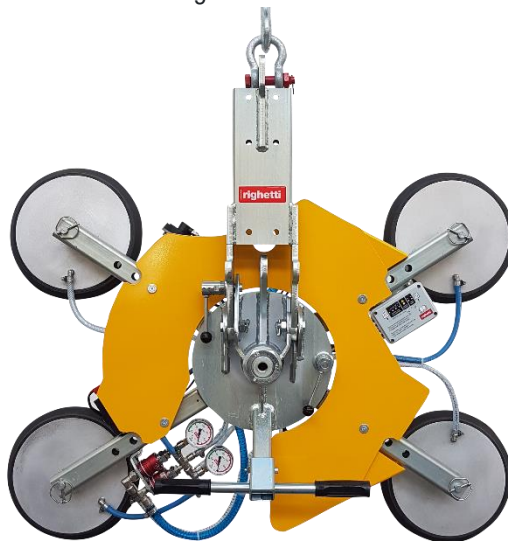
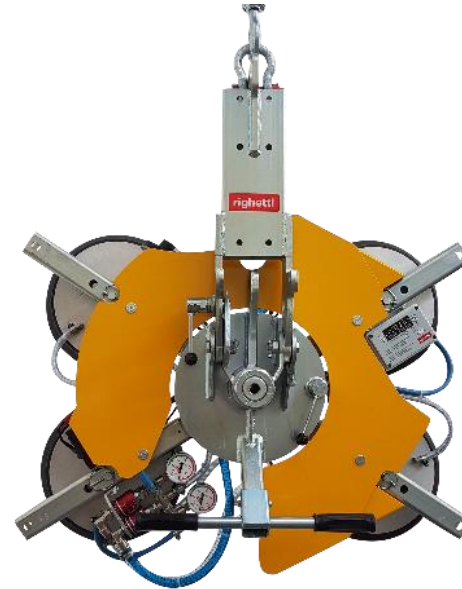

Manual tilt 0-90°



Capacity max 400kg



Manual continuous rotation 360°



Safety devices



4 vacuum pads d.310 mm



Dual vacuum circuit built to EN13155 standard

CE

made in
ITALY

SOSEQUIMENT

760 rue Bériault, Longueuil, Québec (Canada) J4G 1R8
1-833-360-3330 | info@sosequiment.ca

Righetti Vacuum Lifters Specialists

Technical drawing

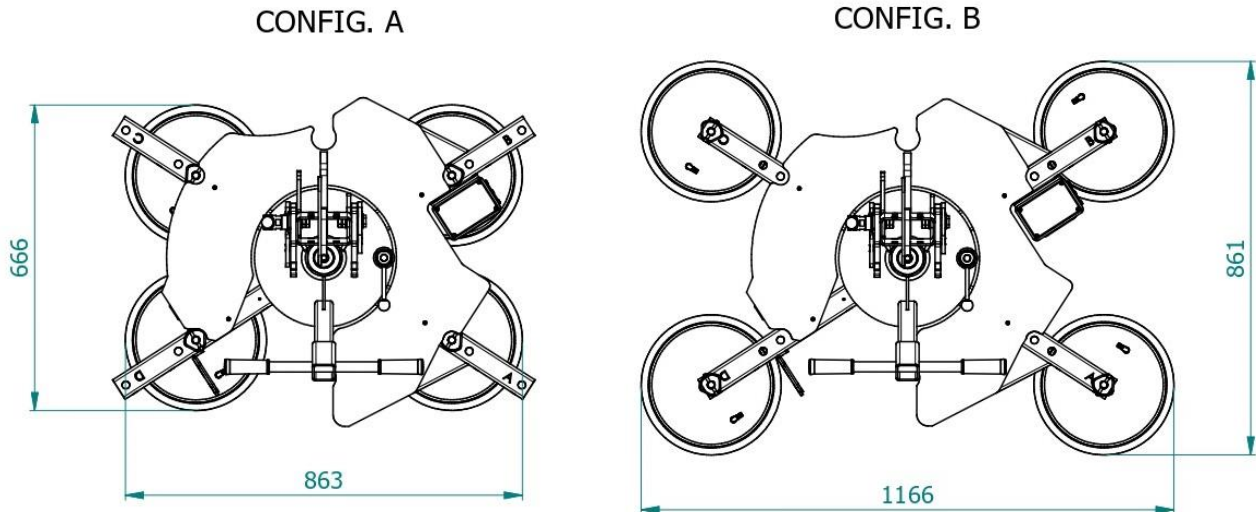

Technical specification

Application	Glass panels
Lifting capacity	Max 400 kg
Suction pads	No. 4 round suction pads diameter 310 mm Lipped pads with safety ring
Pad spread	Repositionable pads in two positions: mm 863 x 666 / 1166 x 861
Load movement	Continuous 360 degree rotation, with possibility of automatic locking at each 90° 90 degree tilt, with possibility of automatic locking in upright and flat position
Operating system	DC vacuum pump powered from on-board batteries High capacity re-chargeable batteries Battery status indicator Economizer for reduction of the energy consumption
Vacuum system	2 independent vacuum circuits, each vacuum circuit with vacuum reserve and non return valve
Weight of lifter	Kg 78
Structural depth	mm 250
Control	Manual on off valve on the lifter's frame Release of the load by dual action security command Remote control as optional
Standard features	Audible and visual low vacuum warning devices Vacuum gauge for each vacuum circuit Battery charger 240 Volt Vacuum filter Multi position hook connection Lowered suspension for installing of transom window