



Model

smart vacuum lifters

GLE4+8 d4

Vacuum glass lifter

 Kg max
1500

 Power supply
Batteries

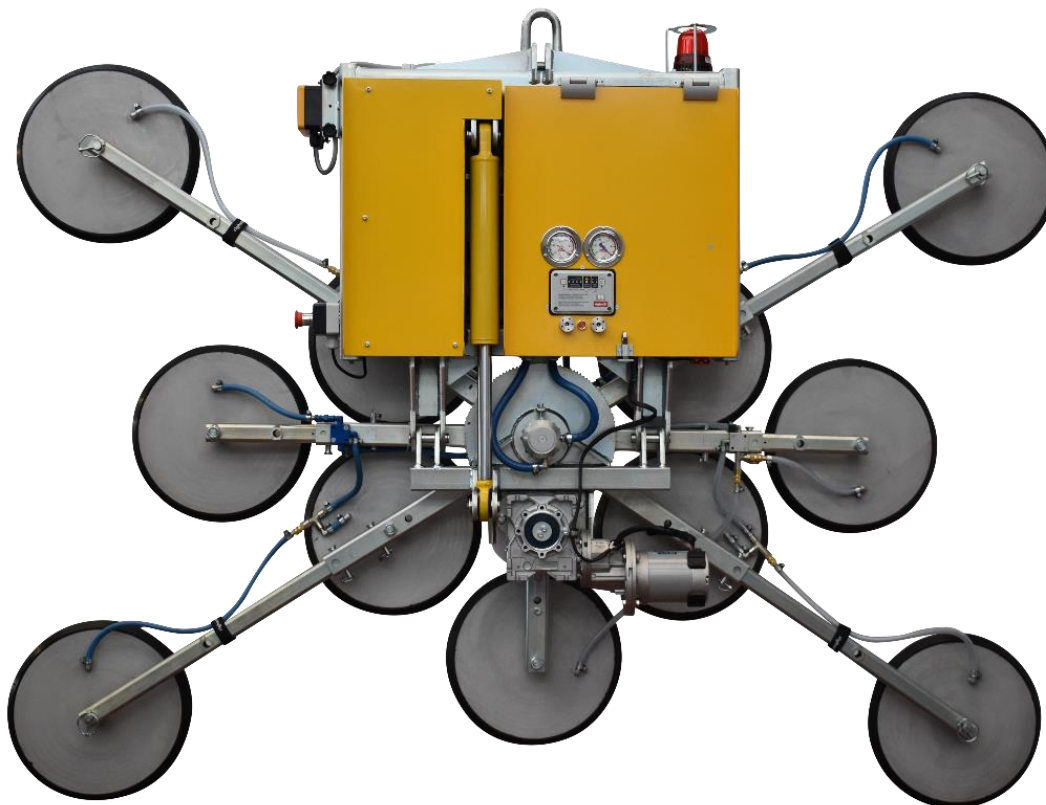

Vacuum glass lifter series GLE4+8 has battery operating system with rechargeable batteries that, if necessary, may be easily removed and quickly replaced.

Vacuum lifter GLE has **compact and slim frame**, only 304 mm width. The lifter offers **hydraulic tilting system and electric 360° continues rotation**. Professional, quality components and strong lifter's frame guarantee safety and reliable lifting and handling also of the big glass elements.

GLE4+8 has 12 suction pads, 4 on lifter's body and 8 on removable extensions. The **extensions permit to modify the lifter's configuration** and lifting capacity adapting the lifter for different glass dimensions.

The pad arms may be removed quickly and easily.

Suction, release, rotation and tilting movements are controlled at distance by **wireless radio remote control**. As optional is available additional siren alarm.



Powered tilt 0-90°



Powered rotation 360°



Max capacity 1500kg



4+8 vacuum pads d.390 mm



Safety devices



Modular frame

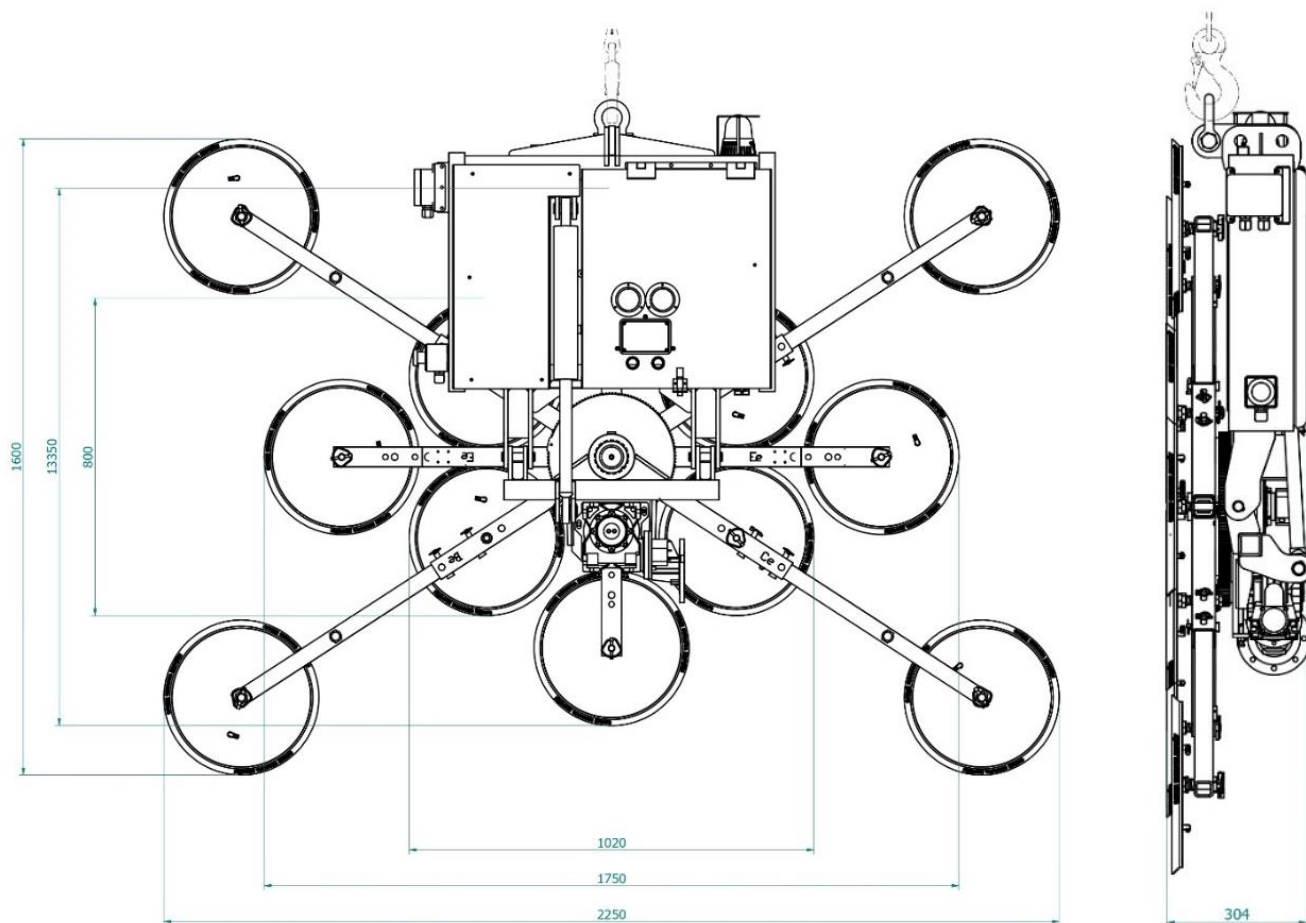

Technical drawing

Technical specification

Application	Glass panels
Lifting capacity	Max 1500 kg
Suction pads	No. 4 + 8 round suction pads diameter 390 mm Lipped pads with safety ring
Pad spread	Pads are movable in different configurations 4 pads mm 1020 x 800 12 pads mm 2250 x 1600
Load movement	Powered 360 degree electric rotation Powered 90 degree hydraulic tilting system
Operating system	DC vacuum pump powered from on-board batteries High capacity re-chargeable batteries Battery status indicator Economizer for reduction of the energy consumption
Vacuum system	2 independent vacuum circuits, each vacuum circuit with vacuum reserve and non return valve
Weight of lifter	Kg 242
Structural depth	mm 304
Control	Tilting, rotation, suction and release are controlled by wireless radio remote control Release of the load by dual action security command
Standard features	Audible and visual low vacuum warning devices Vacuum gauge for each vacuum circuit; vacuum filter Battery charger 240 Volt Multi position hook connection