

MULTITEL MT 162 EX

Mercedes 3500XD PTT = 5000kg

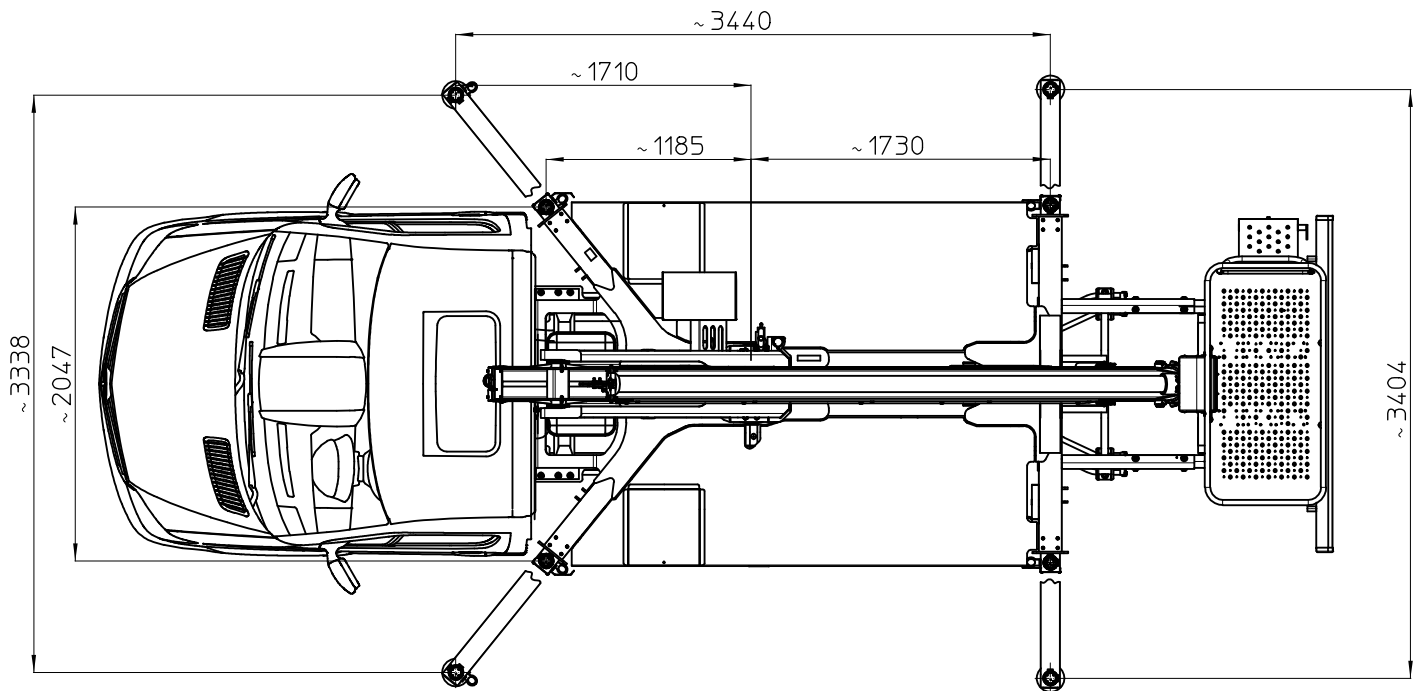
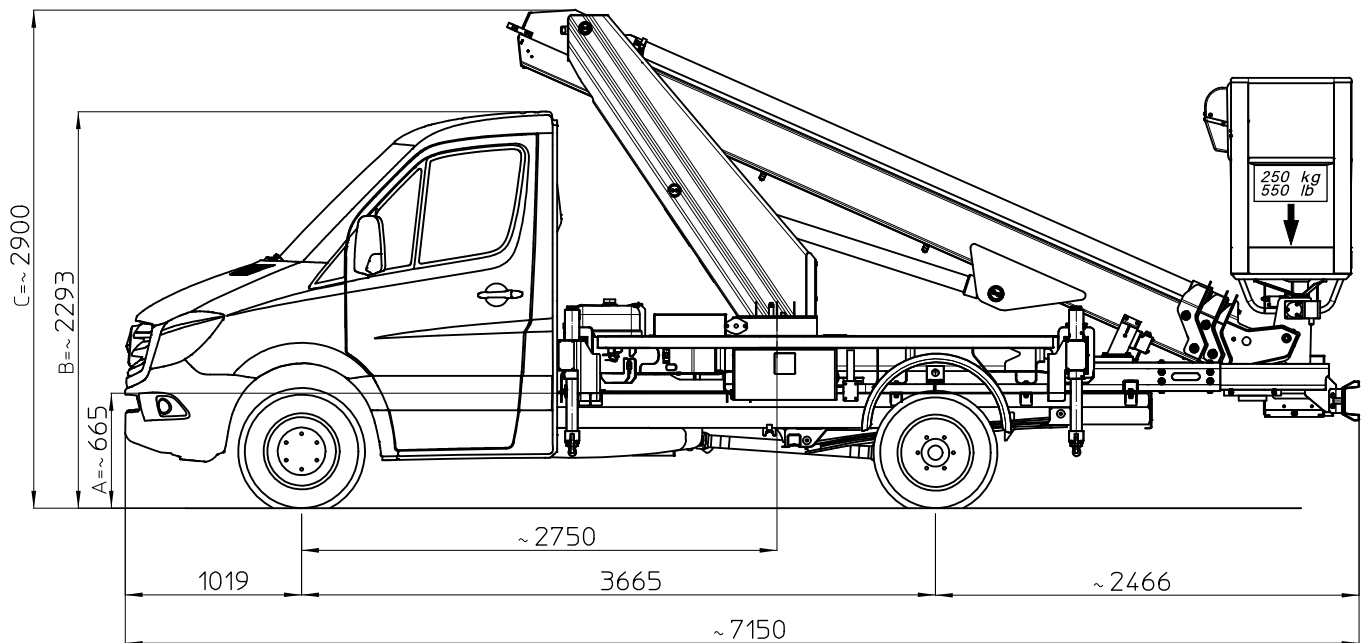

I - Le quote riportate in disegno sono indicative e possono subire variazioni. In particolare le quote A-B sono relative alle dimensioni dell'autocarro, quindi devono essere verificate sullo stesso.

La quota C (altezza totale) e' subordinata alle quote A-B e non comprende eventuali parti flessibili.

F - Les cotes indiquée dans le dessin sont indicatives et peuvent subir des variations. En outre les cotes A-B sont relatives aux dimensions du porteur, donc elles doivent être vérifiées sur le porteur même.

La cote C (hauteur totale) est subordonnée aux cotes A-B est indiquée hors flexibles.

E - The dimensions shown in the drawing are an indication and may undergo changes. Further the dimensions A-B are related to the truck sizes, therefore they must be verified.

The dimension C (total height) is subject to A-B and does not include hoses.

D - Die Maße, die in der Zeichnung gezeigt werden, sind eine Anzeige und können Änderungen durchmachen. Die Abmessungen A-B betreffen die Fahrzeugmasse, daher sollen sie geprüft werden.

Die Abmessung C (Gesamthöhe) hängt von A-B Abmessungen ab, die schlauche sind ausgeschlossen.

1D80431

Ente	Rev.	Descrizione	Data	Dis.	Contr.	Ap.AQ
MRK	0	EMISSIONE	16/11/21	F.Z.	S.G.	F.F.
INGOMBRO - SCHEDA 54/1 - Rev. 0 - 15/12/00						

MULTITEL

MT 162 EX

Ente	Rev.	Descrizione	Data	Dis.	Contr.	Ap.AQ
MRK	1	EMISSIONE	27/09/21	F.Z.		
DIAGRAMMA - SCHEDA 54/2 - Rev. 0 - 15/12/00						

D68484-M

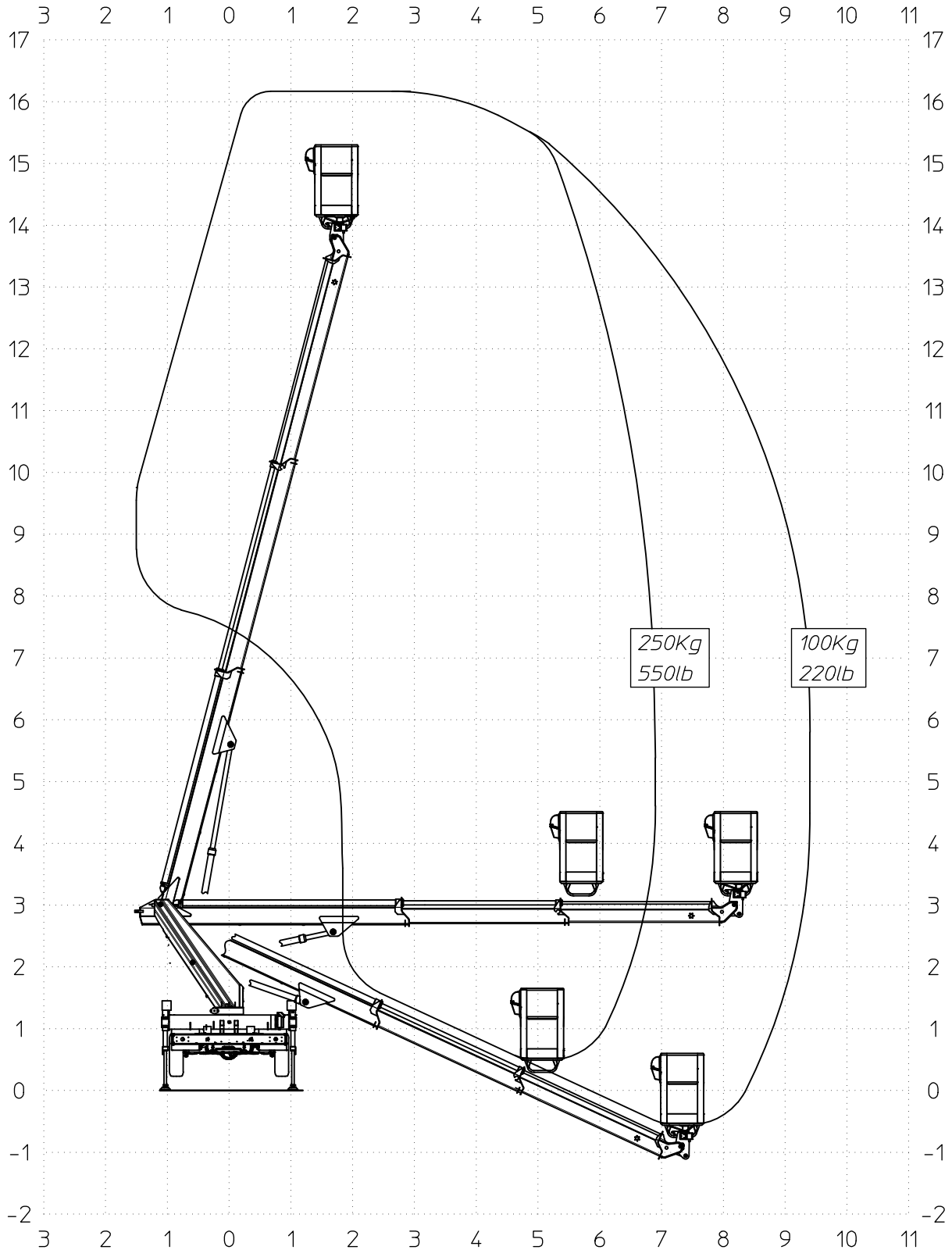

MULTITEL

MT 162 EX

Ente	Rev.	Descrizione	Data	Dis.	Contr.	Ap.AQ
MRK	1	EMISSIONE	27/09/21	F.Z.		
DIAGRAMMA - SCHEDA 54/2 - Rev. 0 - 15/12/00						

D68485-M

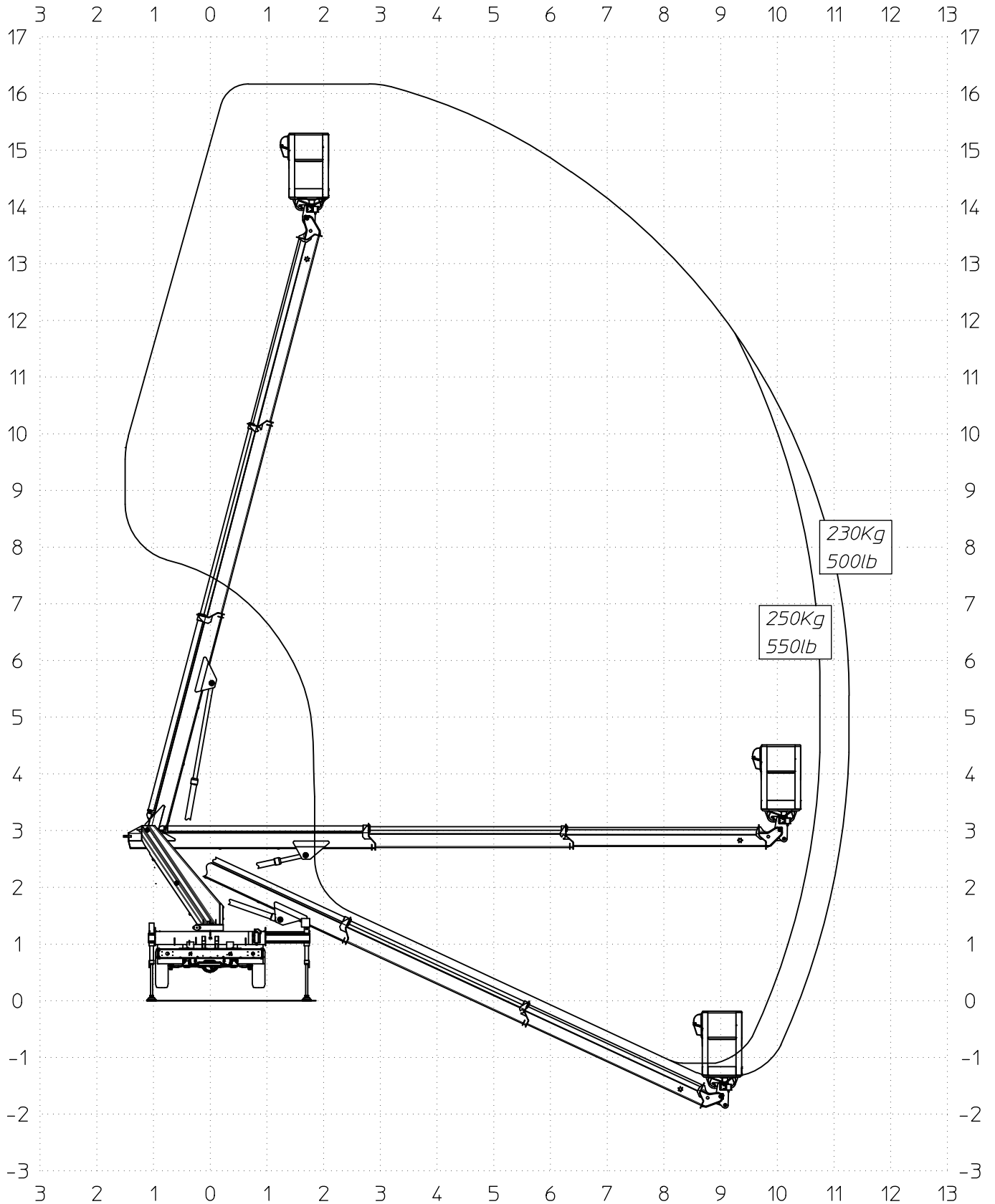

MULTITEL

MT 162 EX

Ente	Rev.	Descrizione	Data	Dis.	Contr.	Ap.AQ
MRK	1	EMISSIONE	27/09/21	F.Z.		
DIAGRAMMA - SCHEDA 54/2 - Rev. 0 - 15/12/00						

D68486-M

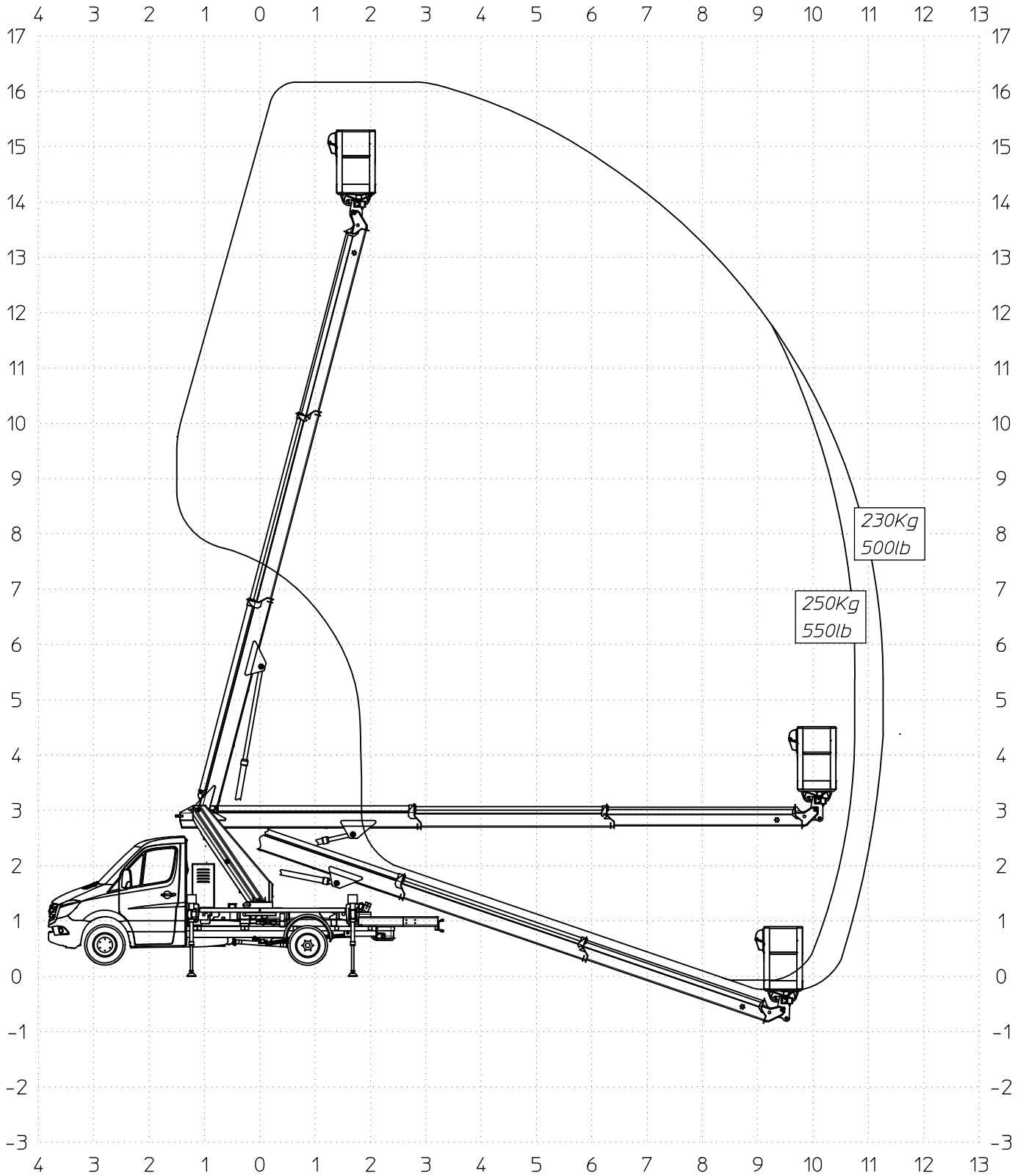

MULTITEL MT 162 EX

Mercedes PTT=5000kg

Ente	Rev.	Descrizione	Data	Dis.	Contr.	Ap.AQ
MRK	0	EMISSIONE	27/09/21	F.Z.		
INGOMBRO - SCHEDA 54/1 - Rev. 0 - 15/12/00						

1D79867-CE

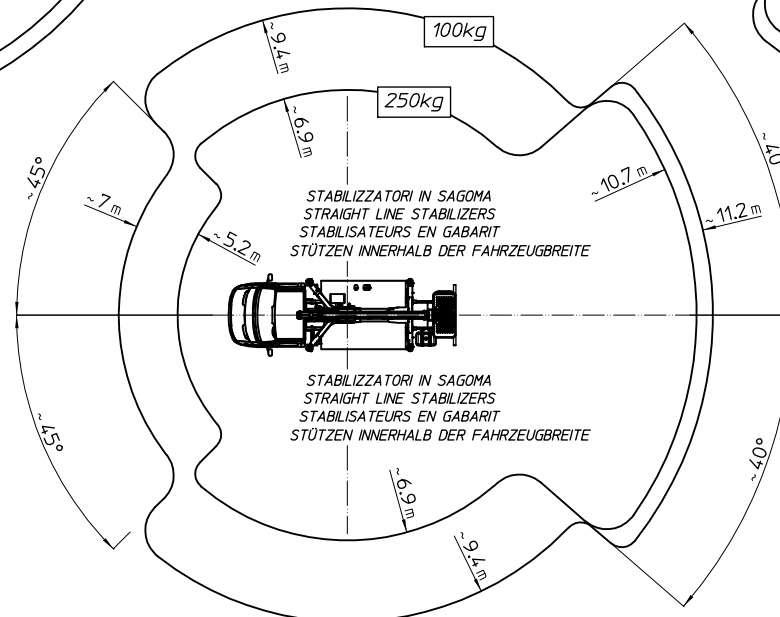
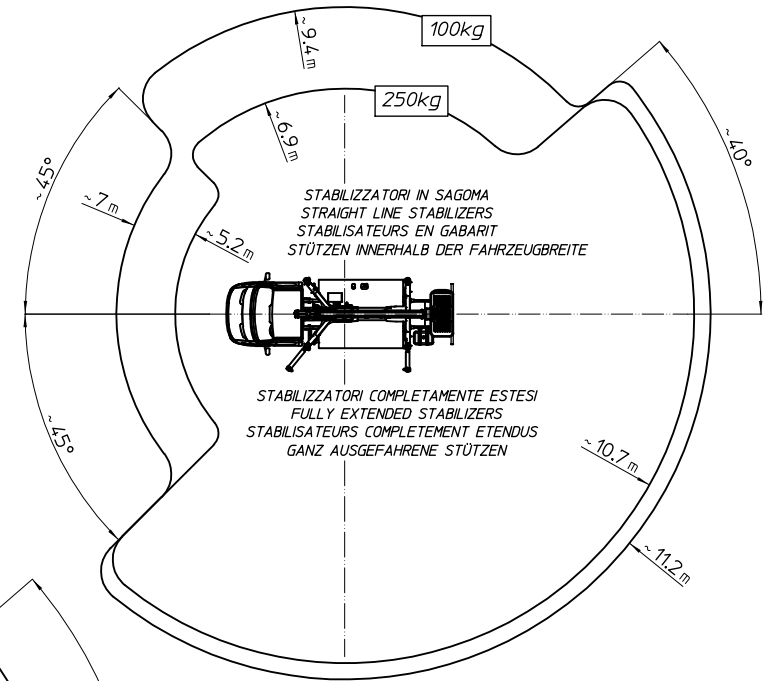
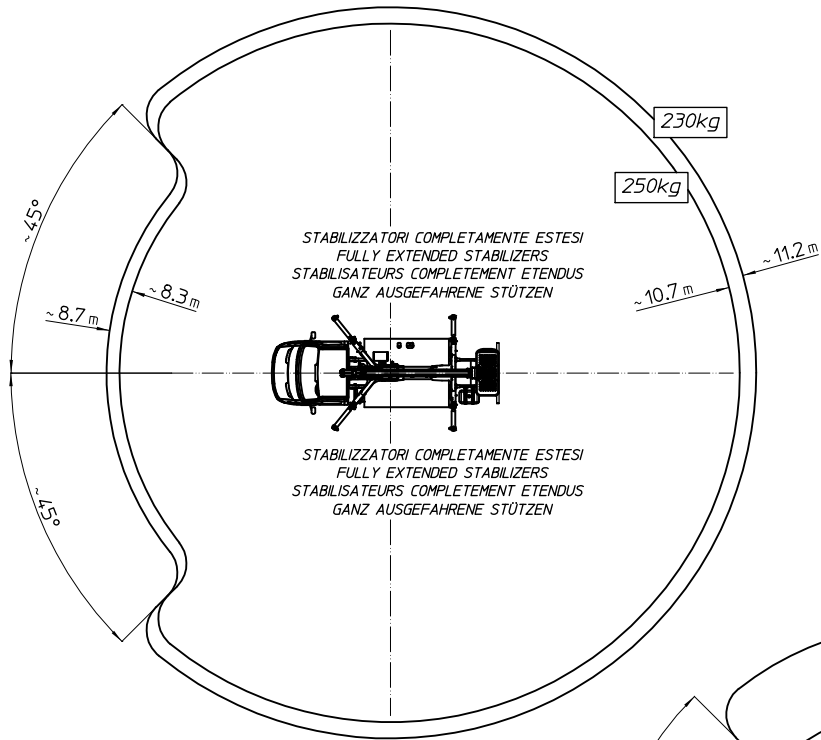

SOSEQUIMENT

760 rue Bériault, Longueuil, Québec (Canada) J4G 1R8
1-833-360-3330 | info@sosequiment.ca