

# Electric Powered Pallet Truck **BLUE GIANT**<sup>®</sup>

## EPJ-40

Ultra compact design is the ideal solution for lift gate and local delivery applications.

### CAPACITY

- 4000 lb (1814 kg)

### BATTERY

- (2) 12-volt AGM 85 AH maintenance-free batteries
- 10A 110V AC plug-in automatic charger

### SPEED

- 24-volt ZAPI AC-0 travel controller
- **EMPTY:** 0 - 3.6 mph (5.8 kph)
- **LOADED:** 0 - 3.3 mph (5.3 kph)

### WEIGHT

- 650 lb (272 kg) (with battery and charger)

### TIRES / WHEELS

- **DRIVE:** 9" x 3" (229 x 76 mm) polyurethane
- **LOAD:** 2.9" x 3.5" (84 x 89 mm) polyurethane

### HYDRAULICS

- Lift cylinder with chrome-plated rods
- Pump unit including motor, solenoid, gear pump, and pressure compensated lowering valve

### ELECTRICAL

- Electric braking
- Quick disconnect EPD power cut off
- Battery discharge indicator and key switch

### BRAKES

- Electromagnetic brake mounted on motor armature shaft, multiplying the braking power through the transmission
- Brake is applied when control arm is in the vertical or horizontal position
- Neutral braking resists rollback on ramps

### OPERATION / CONTROLS

- Ergonomic operator handle with travel, lift, and lower functions
- Angle grips allow easy operation with either hand
- Wrap-around guard
- Reversing switch
- Thumb control
- Key switch and horn
- Low mounted tiller arm offers excellent operator comfort and minimum steering effort
- Gas-assisted spring tiller handle
- Creep speed function with steer handle at 15° back-tilt from vertical



### TRANSMISSION

- Vertically mounted AC drive motor direct mounted to gear housing
- Oil-bathed hypoid bevel gear drivetrain with tapered roller bearings
- State-of-the-art optimized gear technology provides minimal envelope circle, zero maintenance, and low noise level

### ACCESSIBILITY

- Water-resistant
- Removal of three piece power head cover exposes major components for inspection and maintenance

### OPTIONAL EQUIPMENT

- Rubber lug drive tire
- 48" (1219 mm) and 60" (1524 mm) tall load backrest
- Fork width: 22" (559 mm)
- Fork length: 36" (914 mm)
- Tool tray with load restraint
- Stability Casters: 3.3" x 1.9" (74 x 48 mm) polyurethane

 **SOSEQUIPMENT**

ÉLÉVATION | MANUTENTION | ACCESSOIRES

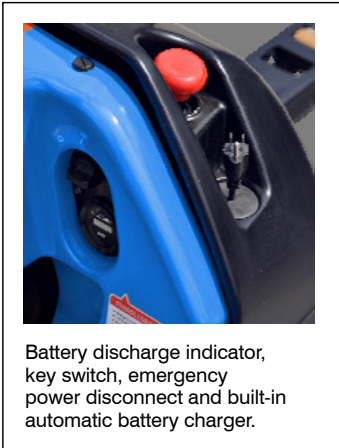

Battery discharge indicator, key switch, emergency power disconnect and built-in automatic battery charger.



Ergonomic operator's handle

Gradeability	
Without Load	10%
With Load	6%
Travel - Variable	
Empty	0 to 3.6 mph
Loaded	0 to 3.3 mph

Dimensions

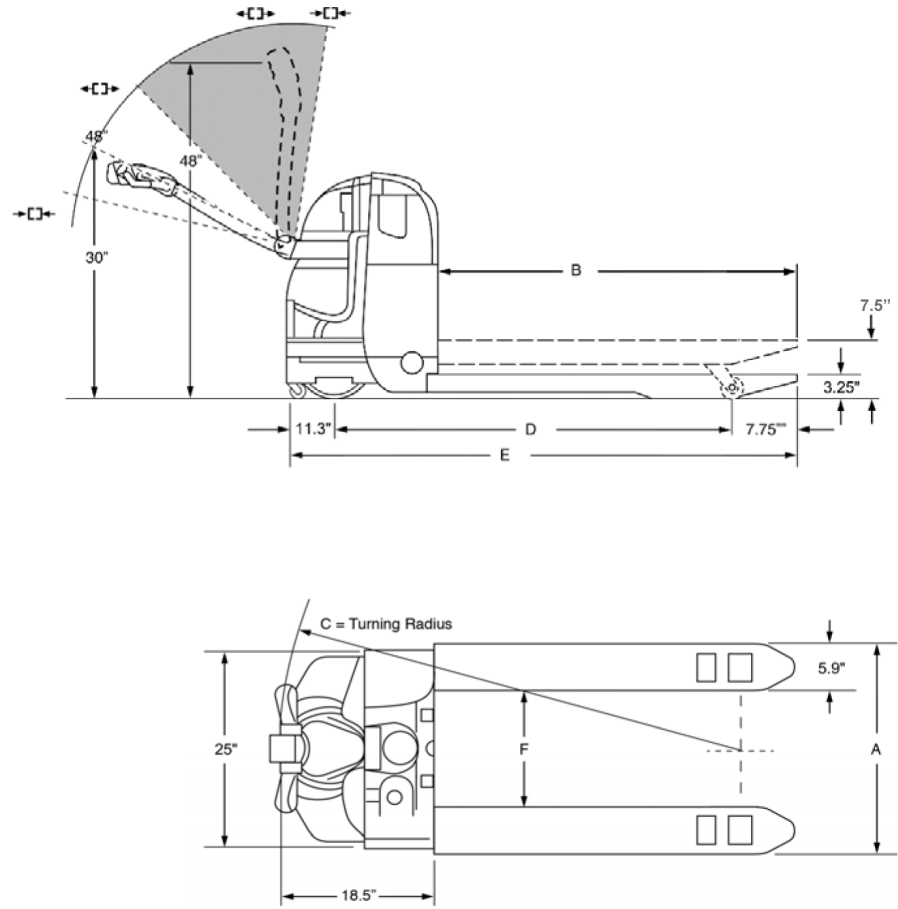

Model#	Forks	Actual Fork Width	Actual Fork Length	Turning Radius	Wheel-base	Overall Length	Inside Fork Width	Weight*	
								lb	kg
<b>Fork Dimension: 27" (686 mm) Wide</b>		<b>A</b>	<b>B</b>	<b>C</b>	<b>D</b>	<b>E</b>	<b>F</b>		
EPJ-40	27" x 36" (686 x 914 mm)	27" (686 mm)	33" (838 mm)	45.5" (1156 mm)	32.95" (837 mm)	52" (1321 mm)	15.2" (386 mm)	635	288
	27" x 48" (686 x 1219 mm)		45" (1143 mm)	57.5" (1461 mm)	51.25" (1302 mm)	64" (1626 mm)		650	295
<b>Fork Dimension: 22" (559 mm) Wide</b>		<b>A</b>	<b>B</b>	<b>C</b>	<b>D</b>	<b>E</b>	<b>F</b>		
EPJ-40	22" x 36" (559 x 914 mm)	22" (556 mm)	33" (838 mm)	45.5" (1156 mm)	32.95" (837 mm)	52" (1321 mm)	9.7" (246 mm)	635	288
	22" x 48" (559 x 1219 mm)		45" (1143 mm)	57.5" (1461 mm)	51.25" (1302 mm)	64" (1626 mm)		650	295

\* Estimated shipping weight with (2) battery



**Corporate** 85 Heart Lake Road South  
Brampton, ON, Canada L6W 3K2  
t 905.457.3900 f 905.457.2313

**USA** 6350 Burnt Poplar Road  
Greensboro, NC 27409  
[www.BlueGiant.com](http://www.BlueGiant.com)



Blue Giant offers a full line of dock levelers, dock safety equipment, seals and shelters, accessories, ergonomic and scissor lift equipment and industrial trucks. Concurrent with our continuing product improvement program, specifications are subject to change without notice. Please contact Blue Giant for latest information. Some features illustrated may be optional in certain market areas.