

E45-70XN



4-WHEEL ELECTRIC FORKLIFT TRUCK CUSHION TIRE PRODUCT TECHNICAL GUIDE



E45-70XN DIMENSIONS

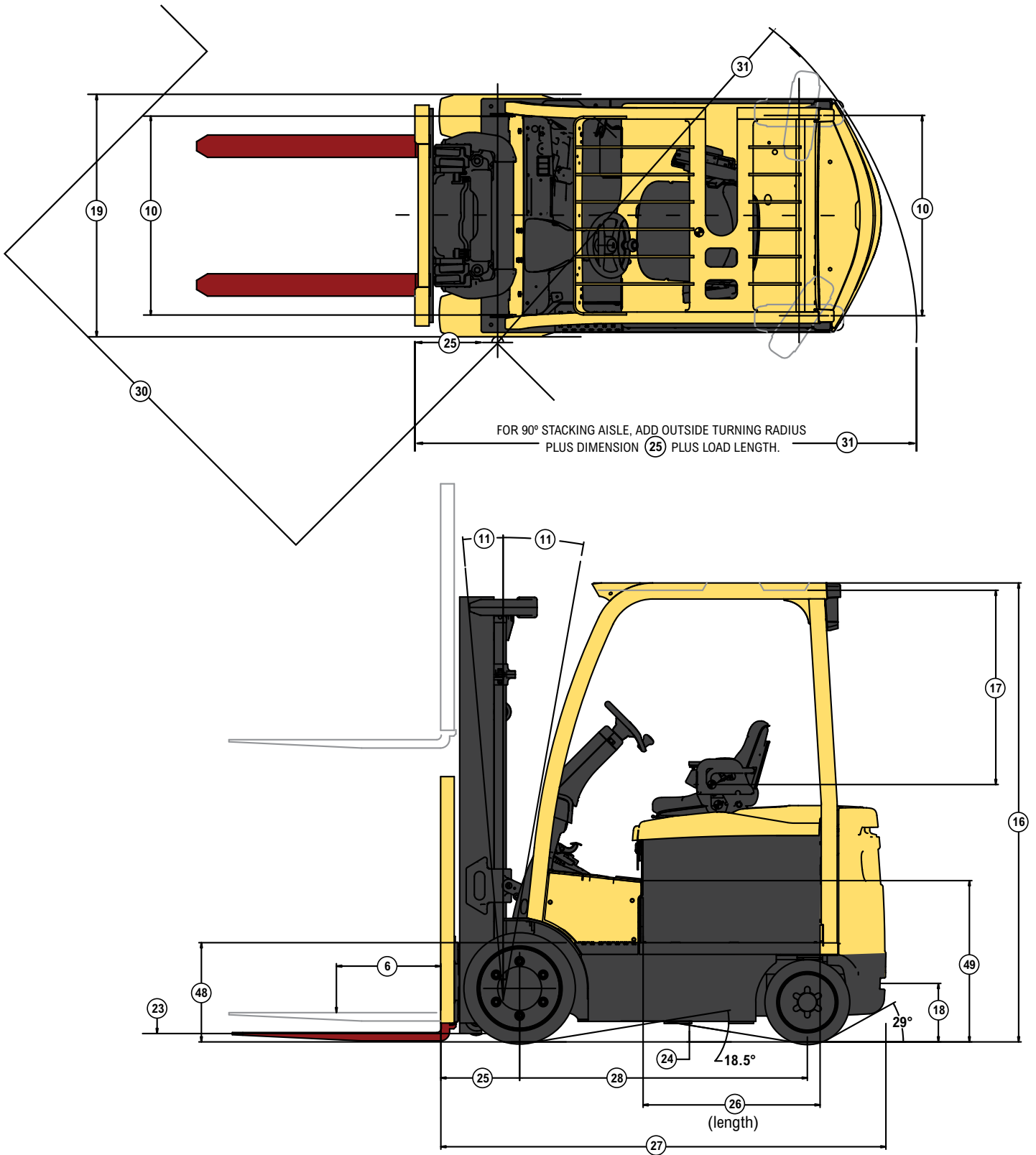

Circled dimensions correspond to the line numbers on the tabulated chart inside the technical guide. Dimensions are in inches (millimeters).

E50XN SPECIFICATIONS

GENERAL	1 Manufacturer			Hyster					
	2 Model designation			E50XN					
	3 Power			Electric					
4 Operation			Sit						
5 Rated capacity			lb (kg)	5000 (2268)					
6 Load center			in (mm)	24 (610)					
TIRES	7 Tire type - cushion, solid, pneumatic, etc.			Drive/steer	Cushion/cushion				
	8 Tire size			Drive/steer	in 21 x 7 x 15 / 16 x 5 x 10.5				
	9 Wheels - number	X=driven	Drive/steer	2x/2					
10 Tread			Tires Std dr/wide dr/steer	in (mm)	35.1/41.9/37 (892/1064/940)				
11 Mast tilt			Std opt opt	degrees	5F/5B 10F/5B (5F/4B)				
12 Mast - lowered height			Std mast	in (mm)	83 (2085)				
13 Free lift - top of fork			Std 2-stg limited free lift mast	in (mm)	5 (140)				
			Opt 2-stg full free lift mast with/without LBR	in (mm)	33/60 (860/1525)				
14 Lift height - top of fork			Std 2-stg limited free lift mast	in (mm)	125 (3192)				
15 Mast - extended height			Std mast with/without LBR	in (mm)	174/148 (4415/3740)				
16 Overhead guard height			Std/drive in rack/opt/opt flat plate	in (mm)	88.5/88.5/86.5/84.1 (2248/2248/2197/2137)				
17 Sip to bottom std OHG			Susp at mid-point Std/susp/swivel	in (mm)	38.3/37.4/37.3 (975/950/948)				
18 Tow pin height			Vertical center of pin	in (mm)	11 (280)				
19 Overall width			Standard tread/wide tread	in (mm)	42.1/48.9 (1070/1242)				
DIMENSIONS	20 Forks			Thickness x width x length	in (mm)	1.6 x 3.9 x 42 (40 x 100 x 1067)			
	21 Standard carriage width			Class II	in (mm)	38.5 (977)			
	22 Floor to top of battery rollers				in (mm)	17.2 (436)			
	23 Ground clearance			Lowest point NL/RL	in (mm)	3.6/3.3 (91/85)			
	24 Ground clearance			Center of truck NL/RL	in (mm)	3.9/3.6 (98/92)			
	25 Load distance			Center of wheel to face of forks	in (mm)	15.4 (390)			
	26 Battery compartment			Height Without/with battery rollers	in (mm)	23.9/23.3 (607/593)			
				Width	in (mm)	39.1 (992)			
				Nominal SIZE		27"	30"	33"	
				Length Actual	in (mm)	27.6 (700)	30.9 (786)	33.3 (847)	
27 Length to face of forks			Chassis length	in (mm)	80.3 (2040)	82.8 (2102)	84.3 (2143)		
28 Wheelbase				in (mm)	48.4 (1230)	51.8 (1316)	54.2 (1377)		
29 Right angle stack				in (mm)	132.5 (3366)	135.2 (3434)	137.5 (3493)		
30 Equal aisle			90° Intersecting aisle	in (mm)	71.8 (1823)	72.5 (1842)	73.1 (1858)		
31 Outside turning radius				in (mm)	69.2 (1757)	71.9 (1825)	74.2 (1884)		
WT.	32 Truck weight			Without battery NI	lb (kg)	7030 (3189)	6670 (3025)	6280 (2849)	
	33 Axle loading - drive			Static w/ max. wt. battery NL/RL	lb (kg)	3844/12907 (1744/5855)	4114/12911 (1866/5856)	4386/13015 (1989/5904)	
	34 Axle loading - steer			Static w/ max. wt. battery NL/RL	lb (kg)	6477/2414 (2938/1095)	6053/2255 (2746/1023)	5796/2166 (2629/982)	
PERFORMANCE					STANDARD PERFORMANCE		POWERPLUS PERFORMANCE		
				VOLTS	36	48	48	80	
	36 Travel speed			Extended shift off NL/RL	mph (km/h)	10.7/9.6 (17.3/15.4)	11.3/11.3 (18.2/18.2)	12.3/12.8 (19.8/20.6)	12.3/12.5 (19.8/20.1)
				Extended shift on NL/RL	mph (km/h)	9.7/8.7 (15.6/14)	10.6/9.8 (17.1/15.8)	12.2/12.4 (19.7/19.9)	12.2/12.2 (19.7/19.7)
	37 Lift speed			Std 2-stg LFL mast NL/RL	ft/min (m/sec)	100/55 (0.51/0.28)	124/75 (0.63/0.38)	142/96 (0.72/0.49)	142/96 (0.72/0.49)
				Opt 2-stg FFL mast NL/RL	ft/min (m/sec)	93/57 (0.47/0.29)	124/77 (0.63/0.39)	130/93 (0.66/0.47)	130/93 (0.66/0.47)
				Opt 3-stg FFL mast NL/RL	ft/min (m/sec)	94/57 (0.48/0.29)	124/77 (0.63/0.39)	134/94 (0.68/0.48)	134/94 (0.68/0.48)
				Opt 4-stg FFL mast NL/RL	ft/min (m/sec)	96/57 (0.49/0.29)	124/75 (0.63/0.38)	136/94 (0.69/0.48)	136/94 (0.69/0.48)
	38 Lower speed			Std 2-stg LFL mast NL/RL	ft/min (m/sec)	100/112 (0.51/0.57)			
				Opt 2-stg FFL mast NL/RL	ft/min (m/sec)	91/106 (0.46/0.54)			
				Opt 3-stg FFL mast NL/RL	ft/min (m/sec)	93/108 (0.47/0.55)			
				Opt 4-stg FFL mast NL/RL	ft/min (m/sec)	77/91 (0.39/0.46)			
	39 Gradeability			5 minute rating NL/RL	%	35/20	36/21	39/25	39/33
				60 minute rating NL/RL	%	13/7	14/8	25/15	32/19
	40 Drawbar pull			5 minute rating NL/RL	LBF	3358/3152	3464/3257	3773/3909	3773/4926
			60 minute rating NL/RL	LBF	1295/1129	1380/1212	2545/2345	3208/2993	
41 Brake			Method of control Service/parking	Hydraulic/mechanical					
			Method of operation Service/parking	Foot/foot					
42 Battery			Type	Lead acid Thin Plate Pure Lead* Lithium-ion*					
ELECTRIC					STANDARD PERFORMANCE		POWERPLUS PERFORMANCE		
				VOLTS	36	48	48	80	
	43 Traction motor			60 minute rating	hp (kW)	24.7 (18.4)	24.7 (18.4)	31.6 (23.6)	31.6 (23.6)
	44 Pump motor			15% rating	hp (kW)	16.6 (12.4)	22.4 (16.7)	31.8 (23.7)	32.2 (24)
	45 Traction motor			Type/control method	AC/transistor				
	46 Pump motor			Type/control method	AC/transistor				
47 Number of speeds			Traction/pump	Infinitely variable/infinitely variable					
OTHER	48 Step height				in (mm)	18.7 (475)			
	49 Floor height			Lowest point	in (mm)	30.4 (772)			
	50 Attachment relief pressure				psi (bar)	2250 (155)			
	51 Auxiliary oil flow			3rd and 4th function	gal/min (l/min)	11 (40)			
	52 Sound level			Measured per ANSI B56.11.5	dB (A)	60	60	65	65

* Optional with Hyster Power Collect™

Above specifications, unless otherwise listed, are for a standard truck without optional equipment.

Right angle stack and equal intersecting aisle dimensions provided with a 48" long and 40" wide pallet load, allowing zero clearance.

MAST DIMENSIONS

E45-55XN MAST DIMENSIONS

Maximum fork height (TOF)	Overall lowered height	Overall extended height		Free lift (TOF)		Approx. total wt. of standard equipped truck w/o battery		
		w/ load backrest	w/o load backrest	w/ load backrest	w/o load backrest	E45XN	E50XN	E55XN
in (mm)	in (mm)	in (mm)	in (mm)	in (mm)	in (mm)	lb (kg)	lb (kg)	lb (kg)

2-STAGE LIMITED FREE LIFT (LFL) VISTA®PLUS MAST

125 (3192)	83 (2085)	174 (4415)	147 (3749)	5 (140)	5 (140)	6860 (3112)	7270 (3298)	6950 (3152)
133 (3392)	86 (2185)	182 (4615)	155 (3949)	5 (140)	5 (140)	7060 (3202)	7470 (3388)	7150 (3243)
137 (3492)	88 (2235)	186 (4715)	159 (4049)	5 (140)	5 (140)	7160 (3248)	7570 (3434)	7250 (3289)

2-STAGE FULL FREE LIFT (FFL) VISTA® MAST

126 (3202)	83 (2085)	175 (4425)	148 (3759)	33 (862)	60 (1528)	6960 (3157)	7370 (3343)	7050 (3198)
133 (3402)	86 (2185)	183 (4625)	155 (3959)	37 (964)	64 (1628)	7160 (3248)	7570 (3434)	7250 (3289)
137 (3502)	88 (2235)	186 (4725)	159 (4059)	39 (1012)	66 (1678)	7260 (3293)	7670 (3479)	7350 (3334)

3-STAGE FULL FREE LIFT (FFL) VISTA®PLUS MAST

189 (4800)	83 (2085)	238 (6023)	210 (5399)	33 (862)	60 (1546)	7460 (3384)	7870 (3570)	7550 (3425)
194 (4950)	85 (2135)	243 (6173)	216 (5489)	36 (917)	62 (1596)	7480 (3393)	7890 (3579)	7570 (3434)
200 (5100)	88 (2235)	249 (6323)	222 (5639)	39 (1012)	66 (1696)	7530 (3416)	7940 (3602)	7620 (3456)
218 (5550)	94 (2385)	267 (6773)	239 (6089)	45 (1162)	72 (1846)	7610 (3452)	8020 (3638)	7700 (3493)
236 (6000)	102 (2585)	285 (7223)	257 (6539)	53 (1362)	80 (2046)	7690 (3488)	8100 (3674)	7780 (3529)

4-STAGE FULL FREE LIFT (FFL) VISTA® MAST

240 (6098)	84 (2133)	289 (7321)	263 (6678)	35 (910)	61 (1553)	8000 (3629)	8410 (3815)	8090 (3670)
252 (6404)	88 (2235)	301 (7627)	275 (6984)	39 (1012)	65 (1655)	8070 (3660)	8480 (3846)	8160 (3701)
264 (6710)	92 (2336)	313 (7933)	287 (7290)	43 (1113)	69 (1756)	8140 (3692)	8550 (3878)	8230 (3733)

E60-70XN MAST DIMENSIONS

Maximum fork height (TOF)	Overall lowered height	Overall extended height		Free lift (TOF)		Approx. total wt. of standard equipped truck w/o battery		
		w/ load backrest	w/o load backrest	w/ load backrest	w/o load backrest	E60XN	E65XN	E70XN
in (mm)	in (mm)	in (mm)	in (mm)	in (mm)	in (mm)	lb (kg)	lb (kg)	lb (kg)

2-STAGE LIMITED FREE LIFT (LFL) VISTA®PLUS MAST

118 (3009)	83 (2085)	167 (4237)	143 (3654)	5 (150)	5 (150)	7570 (3434)	7750 (3515)	7850 (3561)
126 (3209)	86 (2185)	175 (4437)	151 (3854)	5 (150)	5 (150)	7640 (3465)	7820 (3547)	7920 (3592)
130 (3309)	88 (2235)	179 (4537)	155 (3954)	5 (150)	5 (150)	7720 (3502)	7900 (3583)	8000 (3629)

2-STAGE FULL FREE LIFT (FFL) VISTA® MAST

118 (3010)	83 (2085)	167 (4237)	144 (3655)	33 (857)	56 (1440)	7630 (3461)	7810 (3543)	7910 (3588)
126 (3210)	86 (2185)	175 (4437)	151 (3855)	37 (957)	60 (1540)	7670 (3479)	7850 (3561)	7950 (3606)
130 (3310)	88 (2235)	179 (4537)	155 (3955)	39 (1007)	62 (1590)	7810 (3543)	7990 (3624)	8090 (3670)

3-STAGE FULL FREE LIFT (FFL) VISTA®PLUS MAST

175 (4468)	83 (2085)	225 (5696)	200 (5095)	33 (857)	57 (1458)	8050 (3651)	8230 (3733)	8330 (3778)
181 (4618)	85 (2135)	231 (5846)	206 (5245)	35 (907)	59 (1508)	8150 (3697)	8330 (3778)	8430 (3824)
187 (4768)	88 (2235)	237 (5996)	212 (5395)	39 (1007)	63 (1608)	8240 (3738)	8420 (3819)	8520 (3865)
205 (5218)	94 (2385)	254 (6446)	230 (5845)	45 (1157)	69 (1758)	8310 (3769)	8490 (3851)	8590 (3896)
223 (5668)	102 (2585)	272 (6896)	248 (6295)	53 (1357)	77 (1958)	8410 (3815)	8590 (3896)	8690 (3942)

4-STAGE FULL FREE LIFT (FFL) VISTA® MAST

240 (6098)	84 (2133)	289 (7321)	263 (6678)	35 (910)	61 (1553)	8510 (3860)	8690 (3942)	8790 (3987)
252 (6404)	88 (2235)	301 (7627)	275 (6984)	39 (1012)	65 (1655)	8580 (3892)	8760 (3973)	8860 (4019)
264 (6710)	92 (2336)	313 (7933)	287 (7290)	43 (1113)	69 (1756)	8650 (3924)	8830 (4005)	8930 (4051)

E45-70XN BATTERY SPECIFICATIONS

BATTERY AND COMPARTMENT SPECIFICATIONS											
Truck model	Width	Length	Height	"X"	"Y"	"Z"	Volts	No. of cells	Max capacity 6 hour rate	Weight	
										Min	Max
	in (mm)								amp hr (kwh)	lb (kg)	
E45-50XN 27" compartment	39.1 (992)	27.6 (700)	23.9 (607)	38.7 (983)	27.2 (691)	23.5 (597)	36	18	1100 (38.3)	2300 (1050)	3300 (1500)
							48	24	800 (37.2)		
							80	40	375 (29.3)		
E45-50XN 30" compartment	39.1 (992)	30.9 (786)	23.9 (607)	38.7 (983)	30.6 (777)	23.5 (597)	36	18	1200 (41.9)	2500 (1150)	3500 (1600)
							48	24	900 (42)		
							80	40	400 (31.2)		
E45-60XN 33" compartment	39.1 (992)	33.3 (847)	23.9 (607)	38.7 (983)	33 (838)	23.5 (597)	36	18	1300 (45.4)	2900 (1320)	3900 (1770)
							48	24	1000 (46.6)		
							80	40	450 (35.1)		
E65XN 36" compartment	39.1 (992)	36.7 (933)	23.9 (607)	38.7 (983)	36.4 (924)	23.5 (597)	36	18	1500 (52.4)	3100 (1410)	4100 (1860)
							48	24	1100 (51.1)		
							80	40	600 (46.8)		
E65-70XN 40" compartment	39.1 (992)	40 (1015)	23.9 (607)	38.7 (983)	39.6 (1006)	23.5 (597)	36	18	1600 (55.8)	3400 (1550)	4400 (2000)
							48	24	1200 (55.9)		
							80	40	600 (46.8)		

Battery type: "EO" (without cover)

Battery amp hr (kWh) capacity is max allowable per UL

Commercially available lead acid batteries may not necessarily reach these max limits

Battery roller option reduces battery compartment height to 23.3" (593mm) & max battery height to 23.0" (583mm)

Battery compartment length is measured front to rear. Battery compartment width is measured across the truck.

Battery notes - Conventional charging (BCSSBC)

Battery connector: 36-volt - gray SB[®]350 (Anderson Power Products[®] P/N 6320G1 or equivalent)

48-volt - blue SB[®]350 (Anderson Power Products[®] P/N 6321g1 or equivalent)

80-volt - black SBE[®]320 (Anderson Power Products[®] P/N E6363G1 or equivalent)

Battery lead: length 20" (508 mm), position "B", 2/0 AWG

Battery notes - Rapid/fast charging (BARFBC)

Note: A site survey is required to confirm your application is a candidate for rapid charge and to determine the battery and charger specifications required.

Contact your battery and charger supplier.

Battery connector: Requires dual positive/negative cabling terminating in (2) female EBC-320 DIN connectors (Anderson Power Products[®] P/N A32503-0009 or equivalent)

Each individual DIN connector to include 1 red conductor to (+) and 1 black conductor to (-)

Battery lead: Length 25" (635 mm), position "b", minimum cable size 3/0 AWG

PERFORMANCE	STD	OPT
36-volt electrical system	x	
Standard performance	x	
AC traction and pump motors (completely brushless)	x	
Transistor drive and pump control	x	
Advanced VSM (vehicle system manager)	x	
Progressive thermal management system	x	
48 or 80-volt electrical system		x
PowerPlus Performance (N/A with 36-volt)		x
Reverse Speed System		x
DRIVE	STD	OPT
Smooth tread rubber drive tire and steer tire	x	
Non-marking, rubber, or lug tread tires		x
Wide tread tires		x
LIFT	STD	OPT
2-stage limited free lift (LFL) VISTA®PLUS mast* with maximum fork height of 125" (3192 mm) (E45-55XN) or 118" (4800 mm) (E60-70XN)	x	
5° forward and 5° back mast tilt	x	
2-stage full free lift (FFL) VISTA® mast*		
3-stage full free lift (FFL) VISTA®PLUS mast*		x
4-stage full free lift (FFL) VISTA® mast*		
Mast tilt option – 10° forward/5° back		x
Mast tilt option – 5° forward/4° back		x
Return to set tilt		x
Accumulator		x
Load weight indicator		x
HANDLING	STD	OPT
38.5" (980mm) wide Class II (E45-55XN) or Class III (E60-70XN) hook-type carriage with 38.5" (980 mm) high load backrest extension	x	
42" (1067mm) long forks	x	
Carriage with integral sideshift		x
Carriage with integral sideshifting fork positioner		x
Attachment carriages		x
ERGONOMICS	STD	OPT
12" steering wheel with integral spinner knob	x	
Non-suspension vinyl seat	x	
Black, non-cinch seat belt with Emergency Locking Retractor	x	
Foot applied/hand released park brake	x	
Power assist braking	x	
MONOTROL® foot direction control	x	
Auto Deceleration System with regenerative braking	x	
Multifunction display		
– Battery state of charge with low battery lift interrupt		
– Hour meter		x
– Performance mode indicator		
– Fault indicator		
– 4 operator selectable, programmable performance modes		
Easy ingress/egress with low step height and contoured handhold	x	
Operator convenience station - storage areas, beverage & clipboard holders	x	
Adjustable tilt steering column with low profile cowl	x	
Cushioned floor mat	x	
Seatside power disconnect button	x	
TouchPoint electro-hydraulic mini-lever controls with fully adjustable armrest		x
Non-suspension seat (cloth)		x
Full-suspension seat (vinyl or cloth)		x
Full-suspension swivel seat (vinyl or cloth)		x
Seatside directional control		x
Automatic electro-mechanical park brake		x

* For more information, refer to the VISTA®PLUS mast brochure.

ERGONOMICS (continued)	STD	OPT
Telescopic steering column with tilt memory		x
Key switch controlled lights		x
Rear drive handle with integrated horn button		x
Mirrors – rear view or panoramic		x
Synchronous steering		x
Red, high-visibility, non-cinch seat belt with or without start interlock		x
Low mount display		x
OPERATION	STD	OPT
Battery compartment size		
– 27" (E45-50XN)		
– 33" (E55-60XN)	x	
– 36" (E65XN)		
– 40" (E70XN)		
Lift out battery extraction	x	
Standard construction	x	
UL Classification Type "E"	x	
Key switch start	x	
88.5" grid style overhead guard	x	
3-function hydraulic control valve with seatside mechanical levers	x	
Fully integrated CANbus communication	x	
On-demand power steering	x	
Hyster Stability System (HSS®)	x	
Static strap	x	
Tow pin	x	
On-board software: program, test & diagnose; password protected	x	
Electronic horn with integral relay (long life/no adjustments)	x	
Side extraction battery removal with rollers		x
Rapid/fast charge		x
Cooler/freezer package—operating temp: -20°F to +120°F		x
UL Classification Type "EE"		x
4-function hydraulic control valve		x
86.5" grid style overhead guard		x
84.1" flat plate overhead guard		x
88.5" drive-in rack grid style overhead guard		x
Keyless start (with auxiliary key switch)		x
LED and halogen work light packages		x
LED dome/reading light		x
Basic & premium LED brake/tail/back-up light packages		x
Audible alarm – reverse operation (manually adjustable to 87, 97 or 102 dB)		x
Visible amber strobe light - continuous activated, overhead guard mounted		x
Impact monitor		x
Operator password		x
Operator daily checklist		x
System monitor – hydraulic low fluid level indicator and hydraulic filter service indicator		x
Hydraulic attachment extension tubes with quick disconnect fittings		x
Fire extinguisher – 2.5 lb dry chemical		x
Hyster Reaction™		x
SUPPLEMENTAL	STD	OPT
12 month/2,000 hour full truck warranty	x	
36 month/6,000 hour powertrain warranty	x	
Operating manual	x	
ENERGY SYSTEM	STD	OPT
Lead acid	x	
Hyster Power Collect™		x



Hyster Company
P.O. Box 7006, Greenville, North Carolina 27835-7006

© 2024 Hyster-Yale Materials Handling, Inc., all rights reserved. Hyster and  are trademarks of Hyster-Yale Materials Handling, Inc. Hyster products are subject to change without notice. Trucks may be shown with optional equipment.

CERTIFICATION: Hyster lift trucks meet the design and construction requirements of B56.1-1969, per OSHA Section 1910.178(a)(2), and also comply with the B56.1 revision in effect at time of manufacture. Certification of compliance with the applicable ANSI standards appears on the lift truck. Performance specifications/ratings are for truck equipped as described under standard equipment in this technical guide. Performance specifications are affected by the condition of the vehicle and how it is equipped, as well as by the nature and condition of the operating area. Specifications are subject to change and the proposed application should be discussed with your authorized Hyster Company dealer.