

Z

RR 9/200



PL/TFORM
B A S K E T

RAIL ROAD ACCESS PLATFORM

SOSEQUIPMENT

760 rue Bériault, Longueuil, Québec (Canada) J4G 1R8
1-833-360-3330 | info@sosequipment.ca

RR 9/200 Compact, lightweight and versatile for the aerial railway light works.

The new **RR9/200** is the small aerial platform recently developed by Platform Basket in order to make elevated railway maintenance extremely easy.

The project has been realized with the aim of offering extremely light and compact equipment that can be transported by road trailers with a maximum total weight of 3.5 tons and capable of working on railways up to a useful height of 9.5m with 200kg of payload and 2 people on board. RR9/200 offers the possibility of having a self-propelled platform for both rail and civil aerial work.

The equipment designed and developed therefore can be transported to the workplace with the use of pick-ups or vans equipped with tow hooks, with the aid of light trailers that can be used with traditional driving licences and extensions.



The structure of the RR9/200 is composed of an base car designed on track for road and off-road use that offers excellent grip on the ground in any ground condition together with a low specific load particularly designed to allow its movement even in the presence of delicate floors of railway stations.

The base car also offers a system of 2 hydraulically controlled rollers that allow the positioning of the machine from tracks to railway wheels.

But the real advantage of this base car is **the hydraulic rotation of the tracks perpendicular to the 2 railway bogies, which allows easy access to the railway without the need for special alignment manoeuvres.**



The 90 deg tracks swiveling enable an easy and quick in & out from railway track.

The transmission is realized with independent moto-wheels both for the control of the tracked carriage and for the transmission on railway wheels.

Each railway moto-wheel has a negative brake to guarantee the stopping of the equipment in every condition of absence of motive power. In combination with a two-speed system, RR9/200 can be used at a speed of up to 10km/h on the railways.



The power is delivered through a diesel endothermic engine of 10.5 KW power, on request it will also be possible to equip it for fully electric operation with lithium-ion batteries in order to make the equipment suitable for use in tunnels, subways and inside buildings such as hangars, stations, etc.

The upper structure is composed of a 360° rotating turret with automatic levelling of the basket even in the presence of a railway inclination (CANT) up to 180mm with 1435mm of gauge. Its articulated arms make it extremely compact and suitable for entering and leaving the railroad even in the presence of a road open to traffic.

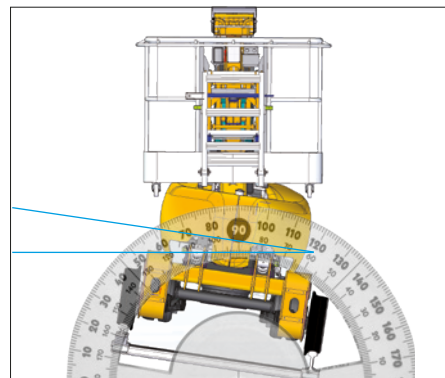

Driving of the machine can be operated by a remote control unit fitted on board of the basket or by the operator at ground with no load in the basket.

Main technical features

- 200 Kg basket self working load
- 9,50 m working height
- 4,70 m side outreach
- Two men basket
- Self levelling of the upper structure on tracks & railway
- Diesel Kubota engine 10,5 kW
- Towable on regular 3,5 Ton GVW trailers
- Removable and interchangeable Basket

Through a sequence of copper braids of 35mm² section, located between the various joints of the platform, the equipotential between the operator basket and the railway track is guaranteed to ensure the safety of personnel on board in the event of electric spikes.

The all-aluminium aerial basket offers sufficient working space with the possibility of accommodating up to 2 people on board (200kg).

Main fields of use:

- In the civil sector, also thanks to the limited weight of the equipment and ground load, it is suitable for maintenance in the shelters of railway station platforms for general maintenance of the same.
- Rail access for light maintenance work, such as signalling, lighting and railway power lines in general.
- In tunnels and in the Underground for general maintenance inside buildings such as stations. Equipment provided with lithium-ion batteries to allow clean energy with 0 emissions.



Ergonomic and intuitive remote control unit enable the easy movements of all machine functions. Operating the RR9 is like a play.



Flexibility at the top operating the machine on tracks or on ground without any stabilization even in narrow doorways.



Anemometer (optional)
For monitoring and warning that the maximum permissible wind speed (45km/h) has been reached.

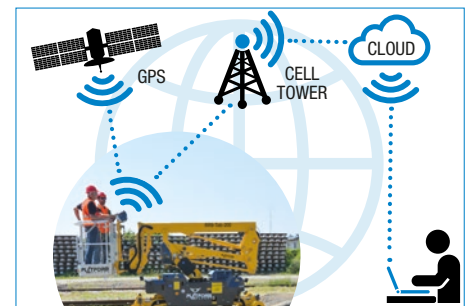

Tele-diagnostics and Geo-location (optional)
Device installed on board the equipment that allows remote control by personnel to maintain the efficiency of the platform.

RR 9/200

Technical specifications (1435 mm gauge)

Max working height (static)	9,50 m
While driving (dynamic)	-
Max. lateral outreach (static)	4,7 m
While driving (dynamic)	-

Rotation angle (mech. Set up)	deg 180° + 180°
Basket rotation	deg 70° + 70°
Lenght in stowed position	4,12 m
Min. stowed width	1,60 m
Min. stowed height	2,30 m
Weight	2900 kg
Max driving speed in travelling mode on railway	10 km/h (Rail)
Max travelling speed in working mode on railway	2 km/h (Rail)
Max driving speed in travelling mode on tracks	2 km/h (Crawler)
Max travelling speed in working mode on tracks	2 km/h (Crawler)
Minimum turning radius (Rail)	<40 m
Max turning slope (CANT)	100 (180)
Main engine power	10.5 kW (14 Hp)
Basket SWL	200 kg
Max allowed wind speed	45 km /h

On the railway envelope

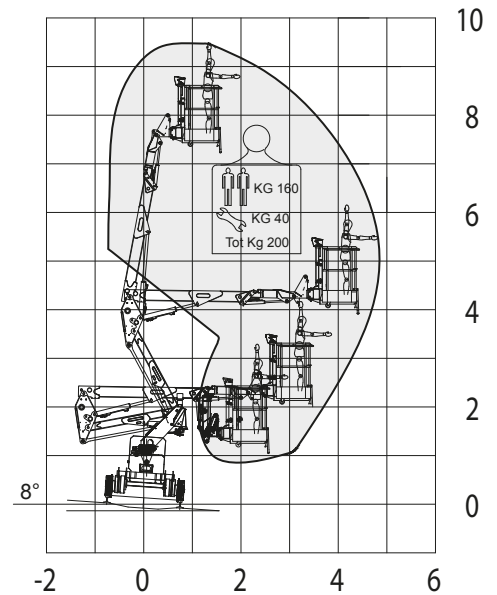

Overall dimensions when on tracks

Maximum horizontal inclination

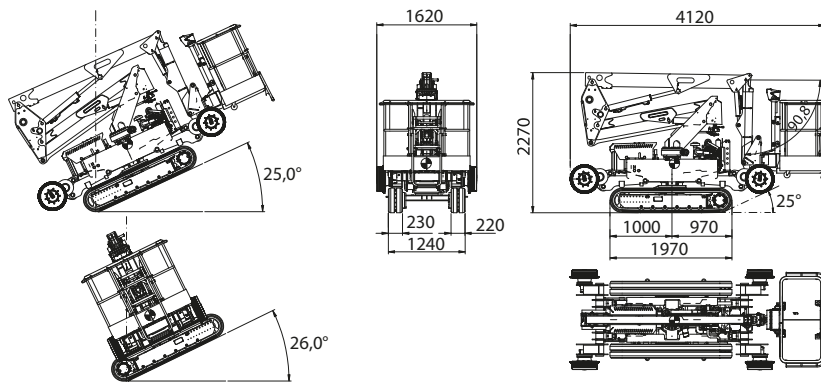

On the road on tracks envelope

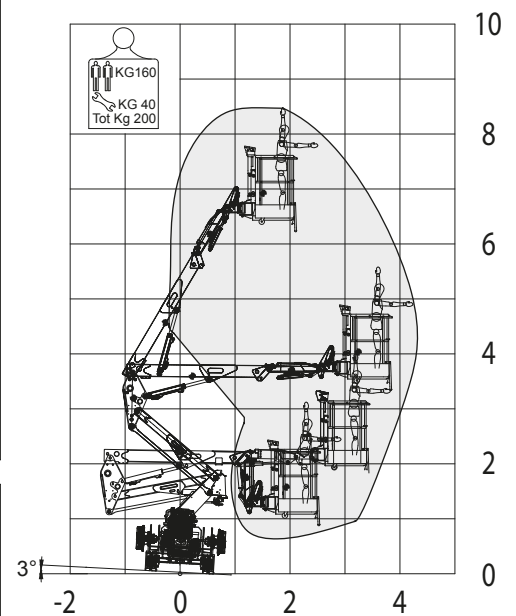

Overall dimensions when on railway (1435 mm gauge)

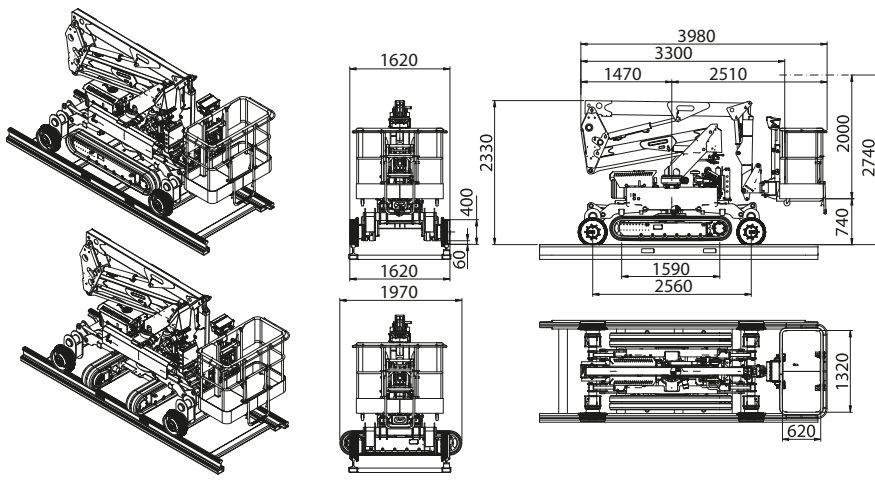

Accessories:

Electric version with lithium batteries
to replace the endothermic engine.

Version designed specifically for work in indoor environments where noise and pollution are prohibited.

Single-seater basket

If the size of the basket affects the positioning of the operator at height, it will also be possible to equip the equipment with a single-seater basket for a single operator, but with better agility in positioning.

Non-marking tracks for base car.

It can also be used inside buildings with delicate floors where the rubber must not leave traces on the ground.

Power generator 220 Vac/ 3 kW



760 rue Bériault, Longueuil, Québec (Canada) J4G 1R8
1-833-360-3330 | info@sosequiment.ca



VIDEO
PROFILE



VIDEO
RR 9/200